

Mac Plus

DC-DC CHARGER

12/12-50, 12/24-30, 24/12-50, 24/24-30, 24/24-50



CE
CZONE®

USER AND INSTALLATION MANUAL

- Ⓔ EN For the latest version of this manual, visit our website:
- Ⓔ NL Ga om deze handleiding in andere talen te downloaden naar onze website:
- Ⓔ DE Um diese Anleitung in anderen Sprachen herunterzuladen, besuchen Sie bitte unsere Website:
- Ⓔ FR Pour télécharger ce manuel dans d'autres langues, consultez notre site Web :
- Ⓔ ES Para descargar este manual en otros idiomas, visite nuestro sitio web:
- Ⓔ IT Per scaricare questo manuale in altre lingue, visitare la pagina del prodotto sul nostro sito Web:

www.mastervolt.com

TABLE OF CONTENTS

1. SAFETY INSTRUCTIONS	4
Warnings and symbols	4
General	4
Explosive gases	5
Warnings regarding the use of batteries	5
Warning regarding life support applications	6
2. GENERAL INFORMATION	7
Use of this manual	7
Liability	7
Warranty	7
Disclaimer	7
Identification label	8
Correct disposal of this product	8
3. PRODUCT DESCRIPTION	9
Dimensions	9
Front panel	10
4. INSTALLATION INSTRUCTIONS	11
5. PLACEMENT AND MOUNTING	12
Adding the Mac Plus to a MasterBus network	12
Adding the Mac Plus to a CZone network	12
6. CONNECTION	13
Installation drawing A	13
Installation drawing B	13
Remote switch input	14
Battery temperature sensor (included)	14
Voltage drop compensation	14
7. CONFIGURATION – DIP SWITCHES	15
8. OPERATION	17
Battery charger operation modes	17
LED indicator	17
9. MASTERBUS	18
What is MasterBus	18
MasterBus on the Mac Plus	18
Monitoring	19
Alarm	20
Configuration	20
Events	23
10. CZONE	25
What is CZone	25
Adding the Mac Plus to a CZone system configuration	25
11. TROUBLE SHOOTING	27

12. TECHNICAL SPECIFICATIONS	29
CZone specifications	30
Battery settings	30
Characteristics	31

1. Safety instructions

This chapter describes important safety and operating instructions for use of a Mac Plus in residential, vehicle (RV) and marine applications.

READ AND SAVE THESE INSTRUCTIONS

Warnings and symbols

Safety instructions and warnings are marked in this manual and on the product by the following pictograms:



CAUTION!

Special information, commands and prohibitions in order to prevent damage.



WARNING!

A WARNING refers to possible injury to the user or installer or significant material damage to the Mac Plus if the installer / user does not (carefully) follow the stated procedures.

General

- 1 Before using the Mac Plus, read all instructions and cautionary markings on the Mac Plus, the batteries, and all appropriate sections of the manual.
- 2 To reduce the risk of electric shock – Do not expose the Mac Plus to rain, snow, spray, moisture, excessive pollution and condensing circumstances. To reduce risk of fire hazard, do not cover or obstruct the ventilation openings. Do not install the Mac Plus in a poorly ventilated room, this may result in overheating.
- 3 Use of an attachment or spare part not recommended or sold by Mastervolt may result in a risk of fire, electric shock, or injury to persons.
- 4 The Mac Plus is designed to be permanently connected to a DC electrical system. Installation of, and work on the Mac Plus, may be carried out only by a qualified, authorized and trained technician or electrician, consistent with the locally applicable standards and regulations.
- 5 Make sure that all wiring is properly installed and in good electrical condition; and that wire size is large enough for DC current rating of the Mac Plus. Check the wiring on a regular base, at least once a year. Do not use the Mac Plus when the wiring is undersized or damaged and replace the wiring immediately.
- 6 Do not operate Mac Plus if it has received a sharp blow, been dropped, or otherwise damaged in any way; take it to a qualified service technician.
- 7 Except for the connection compartment, the Mac Plus may not be opened or disassembled. There are no serviceable parts inside the cabinet. Take it to a qualified, authorized and trained

- service technician when service or repair is required. Incorrect reassembly may result in a risk of electric shock or fire.
- 8 To reduce risk of electric shock, disconnect the Mac Plus from the DC electrical system before attempting any maintenance or cleaning. Turning off controls will not reduce this risk.
 - 9 The Mac Plus may not be used by children or by those who cannot read and understand the manual if they are not supervised by a responsible person who can guarantee that the charger is being used in a safe manner. Keep the charger away from children.
 - 10 Short circuiting or reversing polarity will lead to serious damage to batteries, Mac Plus, wiring as well as accessories. Fuses cannot prevent damage caused by reversed polarity and the warranty will be void.
 - 11 In case of fire, you must use the fire extinguisher which is appropriate for electrical equipment.
 - 12 If applied in a marine application in the United States, external connections to the Mac Plus shall comply with the United States Coast Guard Electrical Regulations (33CFR183, Sub part I).

Explosive gases

- 1 **WARNING – RISK OF EXPLOSIVE GASES. WORKING IN VICINITY OF A LEAD-ACID BATTERY IS DANGEROUS. BATTERIES GENERATE EXPLOSIVE GASES DURING NORMAL BATTERY OPERATION. FOR THIS REASON, IT IS OF UTMOST IMPORTANCE THAT EACH TIME BEFORE USING THE Mac Plus, YOU READ THIS MANUAL AND FOLLOW THE INSTRUCTIONS EXACTLY.**
- 2 To reduce risk of battery explosion, follow these instructions and those published by battery manufacturer and manufacturer of any equipment you intend to use in vicinity of the battery. Review cautionary marking on these products.
- 3 **DANGER:** To reduce the risk of explosion – Never use the Mac Plus in situations where there is danger of gas or dust explosion or area in which ignition-protected equipment is required.

Warnings regarding the use of batteries

- 1 Someone should be within range of your voice or close enough to come to your aid when you work near a battery.
- 2 Have plenty of fresh water and soap nearby in case battery acid contacts skin, clothing, or eyes.
- 3 Wear complete eye protection and clothing protection. Avoid touching eyes while working near battery.
- 4 If battery acid contacts skin or clothing, wash immediately with soap and water. If acid enters eye, immediately flood eye with running cold water for at least 10 minutes and get medical attention immediately.
- 5 NEVER smoke or allow a spark or flame in vicinity of battery or engine.

- 6 Do not short circuit batteries, as this may result in explosion and fire hazard! Be extra cautious to reduce risk of dropping a metal tool onto a battery. It might spark or short-circuit battery or other electrical part that may cause explosion.
- 7 Remove personal metal items such as rings, bracelets, necklaces, and watches when working with a battery. A battery can produce a short-circuit current high enough to weld a ring or the like to metal, causing a severe burn.
- 8 Only use Mac Plus for charging a LEAD-ACID or Lithium-Ion batteries and the supply of loads attached to these batteries, in permanent systems. Do not use Mac Plus for charging dry-cell batteries that are commonly used with home appliances. These batteries may burst and cause injury to persons and damage to property.
- 9 NEVER charge a frozen battery.
- 10 Excessive battery discharge and/or high charging voltages can cause serious damage to batteries. Do not exceed the recommended limits of discharge level of your batteries.
- 11 If it is necessary to remove a battery, always remove grounded terminal from battery first. Make sure all accessories are off, so as not to cause an arc.
- 12 Be sure that the area around battery is well ventilated while battery is being charged. Refer to the recommendations of the battery manufacturer.
- 13 Batteries are heavy! It may become a projectile if it is involved in an accident! Ensure adequate and sure mounting and always use suitable handling equipment for transportation.

Warning regarding life support applications

Do not use the Mac Plus for applications in any medical equipment intended for use as a component of a life support system. For this type of use a specific written agreement between the customer and Mastervolt is required.

2. General information

Use of this manual

This manual serves as a guideline for the safe and effective operation and maintenance of the following Mac Plus models:

Product code	Model
81205105	12/12-50
81205305	12/24-30
81205205	24/12-50
81205405	24/24-30
81205505	24/24-50

These models are further referred to as “Mac Plus”.

Liability

Mastervolt can accept no liability for:

- Consequential damage resulting from the use of the Mac Plus.
- Possible errors in the included manual and the consequences of these.
- Use that is inconsistent with the purpose of the product.

Warranty

The Mastervolt product warranty covers the Mac Plus for the first two years after the purchase date, on the condition that the product is installed and used according to the instructions in this manual. Installation or use that do not comply with these instructions may result in under performance, damage or failure of the product and may void this warranty. The warranty is limited to the cost of repair and/or replacement of the product. Costs of labor or shipping are not covered by this warranty.

Disclaimer

Our products are subject to continual development and improvement. Therefore, additions or modifications to the products may cause changes to the technical data and functional specifications. No rights can be derived from this document. Please consult our most current Terms & Conditions of Sale.

Identification label

Important technical information required for service, maintenance & secondary delivery of parts can be derived from the identification label. The following picture is only an example!

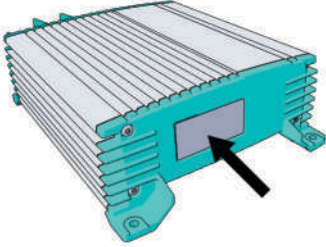

(Serial number N708F0001 with device hardware version F)



CAUTION!

Never remove the identification label. This will void the warranty.

Correct disposal of this product



This product is designed and manufactured with high quality materials and components, which can be recycled and reused. Act according to your local rules and do not dispose of your old products with your normal household waste. The correct disposal of your old product will help prevent potential negative consequences to the environment and human health.

3. Product description

The Mac Plus charger converts a DC (battery) voltage to a regulated DC voltage. It can be used as:

- a 3-Step battery charger or
- a stabilized DC power supply.

The Mac Plus can only be used in installations with a negative ground.

Dimensions

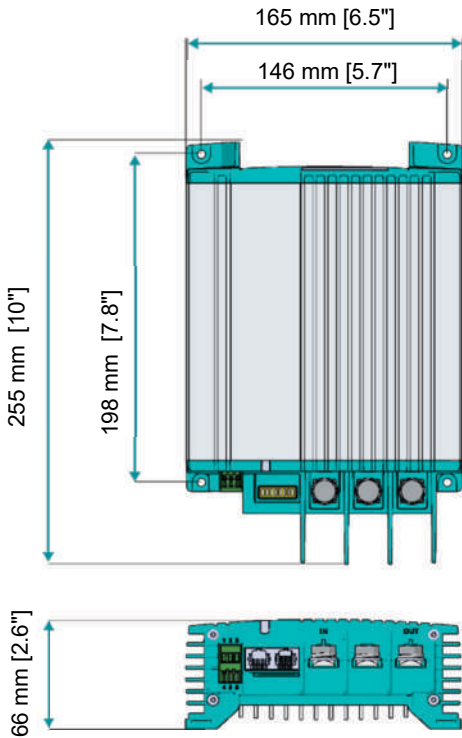

Front panel

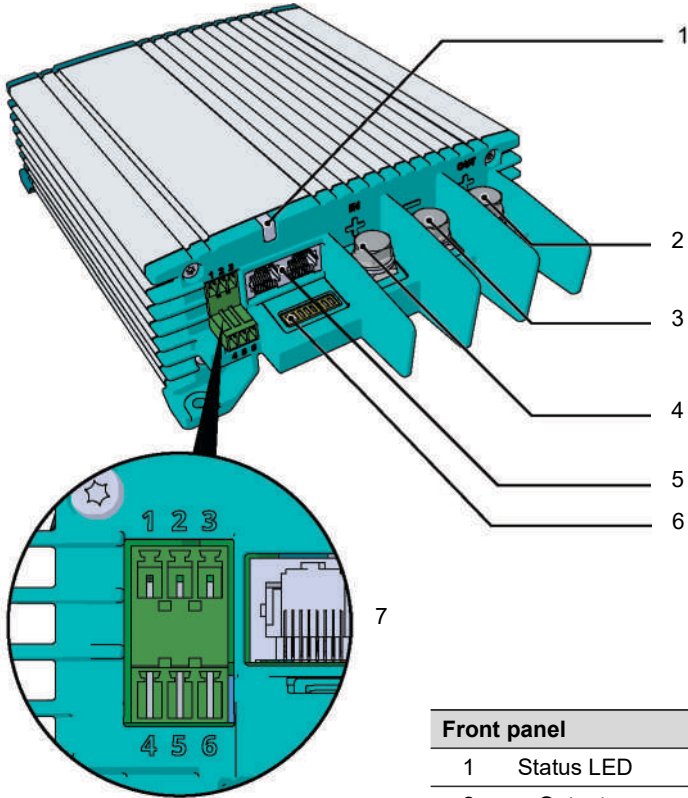

Front panel	
1	Status LED
2	+ Output
3	Ground
4	+ Input
5	MasterBus/CZone connection (2x)
6	DIP switches
7	Accessories connector
	Pin 1: + battery voltage sense input
	Pin 2: - battery voltage sense input
	Pin 3: not used
	Pin 4: remote switch input
	Pin 5-6: battery temperature sensor input

4. Installation instructions

In addition to the Mac Plus the delivery includes:

- Battery temperature sensor;
- Drop cable CZone/MB (1m);
- MasterBus Terminator;
- User and installation manual.

Installation steps:

- 1 Place and mount the Mac Plus, see chapter 5;
- 2 Connect the Mac Plus, see chapter 6;
- 3 Configure the Mac Plus, see chapters 7 and 9 or 10.



CAUTION

Read the entire manual before installing the Mac Plus. Keep the manual at a safe location for future reference.

- Operating temperature range: -20 up to +60 °C, >40 °C derating power [-4 up to +140 °F, >104 °F derating power].
- Never use the Mac Plus at a location where there is danger of gas or dust explosions.
- Mount the Mac Plus in such a way that obstruction of the airflow through the heatsink is prevented. This device requires a minimum of 10 cm (4") of clearance on every side.
- Do not mount the Mac Plus straight above batteries that might release corrosive sulphur fumes.
- Be sure that the output of the supplying source is switched off during installation. Also be sure that no load is connected to the batteries during installation, to prevent hazardous situations.
- Use cables with an appropriate size, see the following table.

Recommended wire sizes DC input/output

Model	Minimum wire size Input	Minimum wire size Output
12/12-50	16 mm ² [AWG 6]	16 mm ² [AWG 6]
12/24-30	16 mm ² [AWG 6]	10 mm ² [AWG 8]
24/12-50	10 mm ² [AWG 8]	16 mm ² [AWG 6]
24/24-30	10 mm ² [AWG 8]	10 mm ² [AWG 8]
24/24-50	16 mm ² [AWG 8]	16 mm ² [AWG 6]

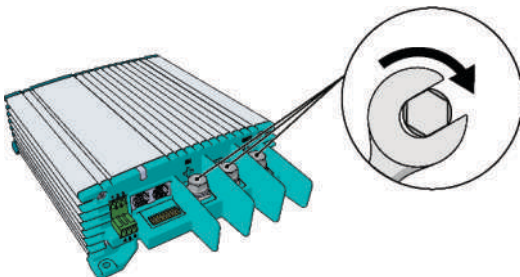

Min. 3 Nm – max. 5 Nm

5. Placement and mounting

Mount the Mac Plus with four M5 screws to a solid flat surface.

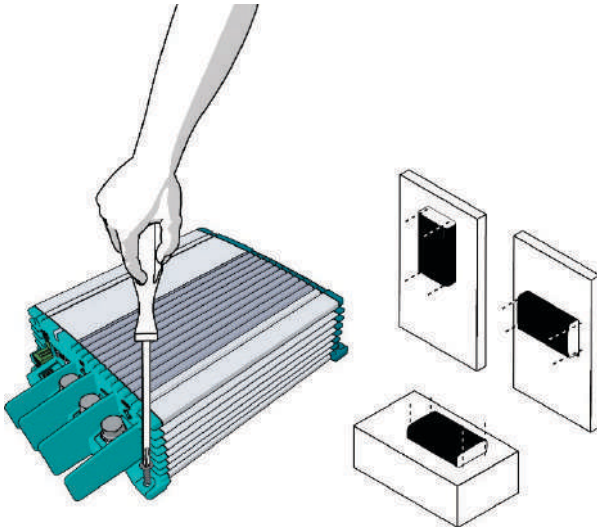

Adding the Mac Plus to a MasterBus network

Precondition: This section assumes that a MasterBus network is already installed.

1. Disconnect a MasterBus cable or Terminator from the closest MasterBus device and connect it to the Mac Plus.
2. Connect the new MasterBus cable to the other MasterBus device and then connect to the Mac Plus.

Adding the Mac Plus to a CZone network

Precondition: This section assumes that a CZone backbone is already installed.

1. Disconnect the backbone at the closest backbone connection and add in a tee connector.
2. Reconnect the backbone connection(s) with the new tee connector in place.
3. Connect the RJ45 CZone/MB drop cable to the black coupler on the tee and then connect to the Mac Plus.

6. Connection

- Mac Plus as a battery charger, see installation drawing A.
- Mac Plus as a stabilized DC power supply, see installation drawing B.
- Use properly sized fuses and wiring.

Installation drawing A

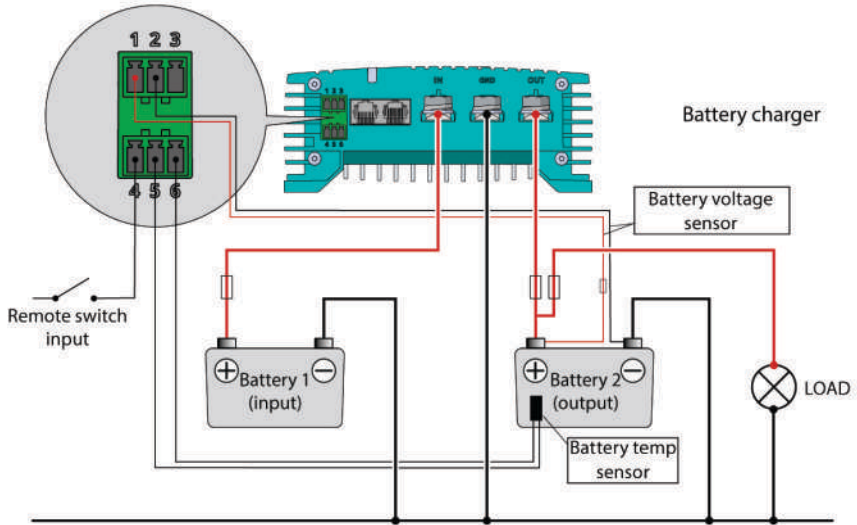

Installation drawing B

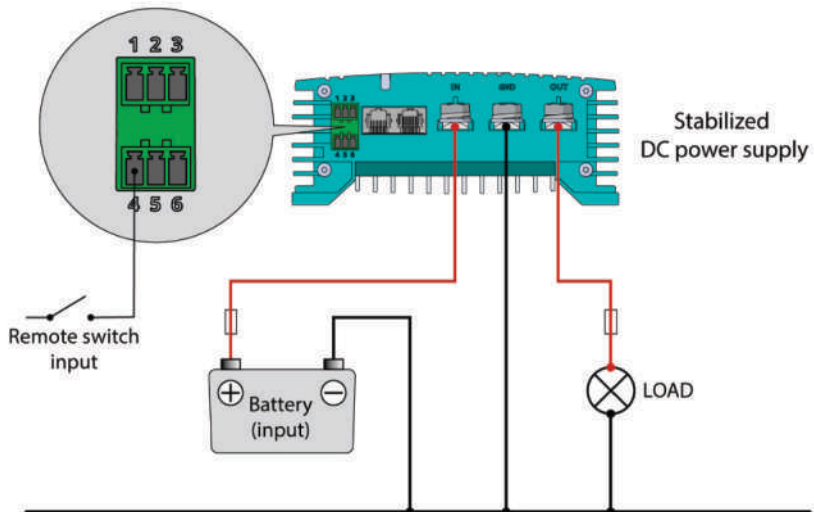

Remote switch input

The remote switch input (pin 4 of the Accessories connector) can be used to enable and disable the battery charger. In a vehicle application, it is recommended to connect the engine run signal. This way, the charger is used when the engine is running and the alternator is charging. The engine run signal can be provided in different ways. For details contact your vehicle distributor.

The remote input accepts two different enable levels:

- active low, connect to ground (between 0 and 0.5 V)
- active high, connect to + battery voltage (between 3 and 32 V)

Active low means active when input is low. Active high means active when input is high.

The remote switch input configuration can be done by DIP switch (see chapter 7) or by MasterBus (see chapter 9) or by CZone (see chapter 10).

Battery temperature sensor (included)

By installing the Mastervolt battery temperature sensor, the charge voltages are automatically adapted for deviating temperatures.

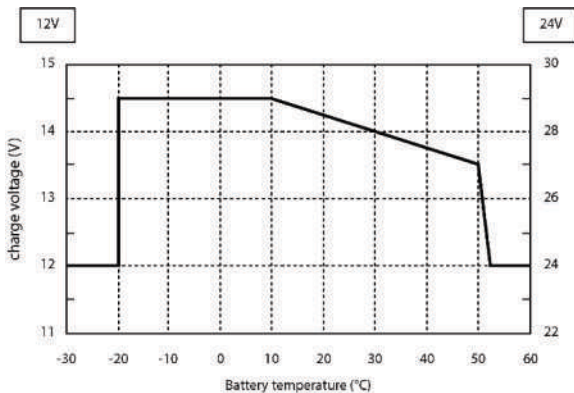

Figure 1. Temperature compensated charging

When the battery temperature is low, the charge voltage increases. In case the battery temperature is high, the charge voltage is decreased. Over charge and gassing are prevented this way. This will extend the life of your battery.

Voltage drop compensation

The Mac Plus can compensate the voltage drop occurring over the output cables. For this purpose, the Mac Plus is equipped with terminals for voltage sense wires. Use 0,75 mm² [AWG 18], preferably red and black wire and protect these with 2 A fuses slow blow. Pay good attention to the polarity of the wires.

In order to accurately measure the battery voltage, connect the voltage sense wires as close to the battery poles as possible. The positive and negative voltage sense wires must be connected. Cable losses will be compensated up to a maximum of 2.5 V.

7. Configuration – DIP switches

The Mac Plus settings can be adjusted in two ways:

- By means of DIP switches;
- From a monitoring panel, for example the EasyView 5 (MasterBus) or the Touch 10 (CZone), or from a computer with MasterAdjust or the CZone Configuration Tool. Some settings can only be changed in this way.

This chapter only describes the DIP switch settings. For settings in a MasterBus network, see chapter 9. For settings in a CZone network, see chapter 10.



CAUTION!

Incorrect settings of the Mac Plus can cause serious damage to your batteries and/or the connected load! Adjustments of settings may be undertaken by authorized personnel only!

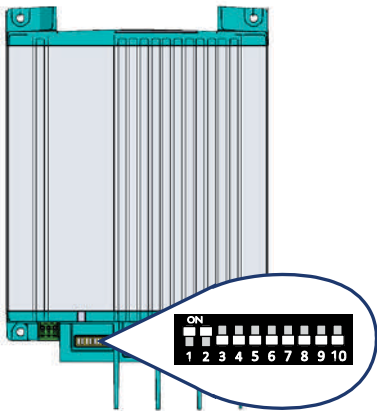

Use a small screwdriver to carefully set the required settings. You may need to remove the cables (or Terminator) to be able to access the DIP switches.

In a CZone network, set DIP switches 1 and 2 to OFF. DIP switches 3 to 10 must match the unique address used in the CZone network; the dipswitch. At least one of DIP switches 3 to 10 must be ON.

In a MasterBus network, set DIP switches 1 and 2 to ON. Use the other DIP switches for charger and battery settings. For an overview of the various DIP switch settings, see the following three tables, where a 0 indicates OFF or ↓ and a 1 indicates ON or ↑.

Note: DIP switch settings overrule MasterBus settings. If DIP switches are not in their default setting, the corresponding MasterBus setting is grayed out.

If a DIP switch is set back to its original setting, the corresponding setting switches back to its default value. For example: in MasterAdjust, battery type Gel was selected. Then DIP switch 3 was set to ON, to select battery type Lithium-Ion. When DIP switch 3 is set back to OFF, the battery type will be Flooded; the default value.

DIP switch		MasterBus communication
2		
0		Smart on; no MasterBus communication in sleep mode (no load <2mA)
1		MasterBus communication always on (no load 10mA), provided there is enough input power

DIP switch			Battery type
3	4	5	
0	0	0	Follow MasterBus setting, see chapter 9. Default factory setting: Flooded battery
0	0	1	Flooded
0	1	0	AGM
0	1	1	Gel
1	0	0	Lithium-Ion
1	1	1	Constant voltage (13.25 V*)

DIP switch			Charger on conditions	Typical use
6	7	8		
0	0	0	MasterBus settings apply, see chapter 9. Default factory setting: Remote switch input 'active high' and input voltage greater than enable voltage setpoint (12.50 V*)	Default factory setting: Recommended setting for vehicle with proper engine run signal
0	0	1	Always on (Remote switch input not used)	When the battery charger must be always active
0	1	0	Remote switch input 'active low'	Enable the battery charger by external operating signal
0	1	1	Remote switch input 'active high'	Enable the battery charger by external operating signal
1	0	0	Remote switch input 'active low' and input voltage greater than enable voltage setpoint (12.50 V*)	Recommended setting for vehicle with proper engine run signal
1	0	1	Remote switch input 'active high' and input voltage greater than enable voltage setpoint (12.50 V*)	Recommended setting for vehicle with proper engine run signal
1	1	0	Input voltage greater than enable voltage setpoint (13.50 V*) (Remote switch input not used)	Higher enable voltage setpoint. Setting for vehicle without engine run signal

* For a 24 V battery charger, multiply the voltages by two.

DIP switches 9 and 10 are not used in MasterBus.





8. Operation

Battery charger operation modes

Mode	Explanation
Charging	The Mac Plus is in charging mode if it meets the switch-on conditions (see DIP switch/MasterBus/CZone settings)
Standby	The Mac Plus goes to standby when it does not meet the switch-on conditions (see DIP switch/ MasterBus/ CZone settings) Or Switched off by the Standby button in a MasterBus menu, or by a MasterBus event, or by a CZone circuit
Sleep (low no-load power consumption)	The Mac Plus enters sleep mode when the sleep delay has passed, to reduce the no-load power consumption Every 5 seconds, the Mac Plus scans if the configured battery charger meets the switch-on conditions
Alarm	Possible error, analyze the situation

LED indicator

Use the following table to understand the meaning of the LED signals.

LED color	LED indication	Meaning	What to do?
Green	 Solid	On	Normal operation
Blue	 Slow blinking	Sleep	Normal operation
Blue	 Solid	Standby	Normal operation
Red-Blue	 Fast blinking	Software update	Update is in progress
Red	 Solid	Possible error	Analyze the situation

9. MasterBus

What is MasterBus



All devices that are suitable for MasterBus are marked by the MasterBus symbol

MasterBus is a fully decentralized data network for communication between the different Mastervolt system devices. It is a CAN-bus based communication network.

MasterBus is used as power management system for all connected devices, such as the inverter, battery charger, generator and many more. This gives the possibility for communication between the connected devices, for instance to start the generator when the batteries are low.

MasterBus reduces complexity of electrical systems by using UTP patch cables. All system components are simply chained together. Therefore, each device is equipped with two MasterBus data ports. When two or more devices are connected to each other through these data ports, they form a local data network, called the MasterBus. The results are a reduction of material costs as only a few electrical cables are needed and less installation time.

For central monitoring and control of the connected devices Mastervolt offers a wide range of panels which show full status information of your electrical system at a glance and a push of a button. See www.mastervolt.com for all available options.

New devices can be added to the existing network in a very easy way by just extending the network. This gives the MasterBus network a high degree of flexibility for extended system configuration, not only today, but in the future as well!

Mastervolt also offers several interfaces, making even non-MasterBus devices suitable to operate in the MasterBus network.

Keep the following rules in mind:

- Connections between the devices are made by standard MasterBus cables (straight UTP). Mastervolt can supply these cables.
- As with all high-speed data networks, MasterBus needs a terminating device on both ends of the network.
- Up to 63 MasterBus devices can be connected together.
- The electric power for the network comes from the connected devices. At least one device in the network should have powering capabilities (see specifications). One powering device can power up to three non-powering devices. As all powering devices are galvanically isolated, multiple powering devices are allowed. Spread the powering devices over the network.
- Do not make ring networks.
- Do not make T-connections in the network.

For more details on networks, please contact your Mastervolt supplier.

MasterBus on the Mac Plus

When the Mac Plus is connected, open MasterAdjust on a Windows computer connected to the MasterBus network via a MasterBus USB interface. MasterAdjust software is available as free to download software on the Mastervolt website: www.mastervolt.com.

The following tables list the parameters as shown in MasterAdjust.

Monitoring

Value	Meaning	Adjustable range
Status		
Device state	Shows the actual operation mode: Standby / Charging / Alarm	(read only)
Charge state	State of charge algorithm: Off / Bulk / Absorption / Float / Constant voltage	(read only)
On/Standby	Button to toggle the device state. Note: in the standby mode, the Mac Plus can be switched on again automatically. This happens, for example, after a restart.	On, Standby
DC in		
Input voltage	Voltage at the input	(read only)
Input current	Current of the input	(read only)
DC out		
Output voltage	Voltage at the output	(read only)
Output current	Current of the output	(read only)
Bat. volt sense	Battery voltage measured by the battery voltage sensor.	(read only)
Remote		
Remote input	Remote input signal detected. Only applicable when Remote input mode is active low or active high configured.	(read only)
Temperature		
Battery	Actual battery temperature measured by the Battery temperature sensor. If no battery temperature sensor is used or when Battery is set to "Lilon": "---" is shown.	(read only)
Device	Device temperature	(read only)

Alarm

Value	Meaning
Dev. temp. high	Internal temperature is too high
Bat. temp. high	Battery temperature is too high (> 55 °C [131 °F])
Bat. temp. low	Battery temperature is too low (< -20 °C [-4 °F])
Input high	Input voltage is too high
Input low	Input voltage is too low
Output high	Output voltage is too high
Output low	Output voltage is too low
Over volt. prot.	Over Voltage Protection shutdown
Over curr. prot	Over Current Protection shutdown
HW fault	Internal hardware error
Cable loss high	Cable loss is too high (>2.5 V)

Configuration

Value	Meaning	Factory setting	Adjustable range
Device			
Name	Name of this device. This name will be recognized by all devices connected to the network	Plus 12/12 Plus 12/24 Plus 24/12 Plus 24/24 Plus24/24-50	0-12 chars
Language	Menu language of this device	English	EN, NL, DE, FR, ES, IT, NO, SV, FI, DA
CZone enabled	This checkbox is marked when the Mac Plus is setup to work in a CZone network	Off	(read only)
DIP switches	DIP switch state 0=off, 1=on	1100000000	(read only)
Factory settings	Button to reset the Mac Plus to default settings (requires installer rights)		
Config locked	Option to lock the configuration (requires installer rights)	Off	On, Off

Value	Meaning	Factory setting	Adjustable range
Remote input			
Mode	Active low: active when the input voltage is 0 - 0.5 V Active high: active when the input voltage is 3 - 32 V Not used: always active	Active high	Not used, Active low, Active high
Input threshold			
Enabled	Enabled: input voltage thresholds are active Disabled: input voltage thresholds are not active	Enabled	Enabled, Disabled
Enable voltage	Enable input voltage	12.50 V*	8-16 V*
Enable delay	Enable delay	2 s	0-300 s
Disable voltage	Disable input voltage	12.00 V*	8-16 V*
Disable delay	Disable delay	300 s	0-300 s
Instant disable	Disable input voltage, no delay	11.00 V*	8-16 V*
Sleep delay	Delay before the Mac Plus switches to sleep mode	300 s	0-3600 s
Charger			
Battery type**	Selection of pre-set charge settings. Individual adjustments are only possible if "User defined" is selected here.	Flooded	Flooded, Gel, AGM, Lilon, User defined
Method	Charge method	3-Step+	3-Step+ (1UoU), Constant voltage (13.25 V*)
Max output (limit)	Maximum output (charge) current	50 A / 30 A	0-50 A / 0-30 A
Max input (limit)	Maximum input current	50 A / 30 A	0-50 A / 0-30 A
Current ramp up	Charge current ramp up after enabling the charger.	5 A/s	0-50 A/s
Temp. compensate	Temperature compensation for charge voltage	-0.030 V/°C	-0.1 - +0.1 V
Bulk			
Bulk voltage	Bulk voltage	14.25 V*	8-15 V*
Max bulk time	Maximum bulk time	480 min	0-1440 min
Min bulk time	Minimum bulk time	120 s	0-240 s
Start bulk time	Start bulk timer	13.25 V*	8-15 V*

Value	Meaning	Factory setting	Adjustable range
Absorption			
Abs. voltage	Absorption voltage	14.25 V*	8-15 V*
Max absorp. time	Maximum absorption time	240 min	0-1440 min
Min absorp. time	Minimum absorption time	15 min	0-240 min
Return amps	Return amps (% of maximum charge current)	6 % or 10 %	0-50 %
Float			
Float voltage	Float voltage	13.25 V*	8-15 V*
Bulk ret. volt	Return to bulk voltage	12.80 V*	8-15 V*
Bulk return time	Return to bulk time delay	30 s	0-240 s
Constant voltage			
Constant voltage	Constant output voltage	13.25 V*	8-15 V*
Input alarm			
High alarm on	High input voltage alarm on	16.00 V*	8-16 V*
High alarm off	High input voltage alarm off	15.50 V*	8-16 V*
Low alarm off	Low input voltage alarm off	11.00 V*	8-16 V*
Low alarm on	Low input voltage alarm on	10.00 V*	8-16 V*
Low alarm delay	Low input alarm delay time	5 s	0-300 s
Output alarm			
High alarm on	High output voltage alarm on	15.25 V*	8-16 V*
High alarm off	High output voltage alarm off	14.75 V*	8-16 V*
Low alarm off	Low output voltage alarm off	11.00 V*	8-16 V*
Low alarm on	Low output voltage alarm on	10.00 V*	8-16 V*
Low alarm delay	Low output alarm delay time	30 s	0-300 s

* For a 24 V battery charger, multiply the voltages by two.

** For an overview of charging specification, see section "Battery settings" on page 30.

Events

A MasterBus device can be programmed to initiate an action at another connected device. This is very helpful in automation of your system but is not required. In MasterBus this is done by means of event-based commands. In the Events tab you can program the Mac Plus to act as an event source. Events which occur during the operation of the Mac Plus will then trigger actions from other products.

Field	Meaning	Value
Event x source	Select an event that triggers an action, for example Battery pre low.	See <i>Event source</i> list
Event x target	Select the device that should take action, for example the generator	Selectable targets are system dependent
Event x command	Select the parameter that must be changed on the target device, for example Activate.	See command list of the selected device
Event x data	Data translates the input into an output.	Off, On, Copy, Copy Invert, Toggle

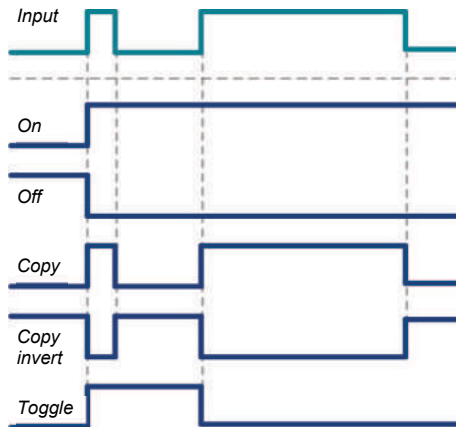

- On: status changes to On at first input signal.
- Off: status changes to Off at first input signal.
- Copy: status follows input signal.
- Copy invert: status follows opposite of input.
- Toggle: status changes at 1st signal and back at the 2nd.

The Mac Plus can be configured as an *event source*. An event source can be used to initiate an *event command* and an *event action* by another device.

Event source	Meaning
Standby	Device state is Standby
Bulk	State of charge is Bulk
Absorption	State of charge is Absorption
Float	State of charge is Float
Alarm	Any of the alarms is triggered

When the Mac Plus is configured as an *event target* by another device, this device can initiate an *event command* and an *event action* to be performed by the Mac Plus.

Event command	Meaning
Standby	Command to switch on/off the Mac Plus. If the Mac Plus was switched off by means of this event command, it will switch on again when it wakes from sleep mode (i.e. after meeting the switch-on conditions, see DIP switch/MasterBus settings).
Bulk	Command to start the Bulk state of charge
Absorption	Command to start the Absorption state of charge
Float	Command to start the Float state of charge

10. CZone

What is CZone

The CZone® network is an NMEA 2000-compliant CAN-based system. Either do the configuration while connected to the network or use a prepared configuration file (.zcf). Ensure that a DIP Switch is assigned.

Note: CZone is supported by Mac Plus models that have 10 DIP switches.

Adding the Mac Plus to a CZone system configuration

Precondition: This section assumes that a CZone system is already configured and the CZone Configuration Tool is open.

1. In the CZone Configuration Tool, from the **Modules** tab, press the **Add** button.
2. From the **Module Type** drop-down list select **DC/DC Converters**.
3. From the **Charger Type** drop-down list select the required Mac Plus model.
4. Enter an understandable **Module Name**.
5. Each device on a CZone network has a unique CZone address, the **Dipswitch**. This number must match the physical DIP switch settings. When connected to the system: either select one from the drop-down list or edit graphically.
6. Select the **Battery Type** (Flooded, Gel, AGM, Lithium-Ion, or User defined).
For an overview of charging specification, see section "Battery settings" on page 30.
7. Enter the required output **Current Limit (A)**.
8. Option: press the **Advanced Settings** button to configure advanced options.
 - For battery types other than "User defined":
 - Select the **Charge Method** (3-Step+, or Constant voltage).
 - Enter the input **Maximum Current**.
 - From the **Remote Input, Mode** drop-down list, select the required enable level:
 - Active low: active when the input voltage is 0 - 0.5 V
 - Active high: active when the input voltage is 3 - 32 V
 - Off: always active
 - Select **Enable Threshold** if you want to change the settings.
 - For battery type "User defined", also the bulk, absorption and float settings can be adjusted.
 - NMEA2000 Instances are used to differentiate between multiple monitoring sources. PGNs are identifiers for information that follows. See page 30 for an overview of supported PGNs.
9. Press **OK** to return to the Module Modification window and press the **Alarm/Switch Settings** button.
10. Select the required Alarm Severities.
11. Press **OK**.

12. Option: Press the **Circuits** tab to **Add** a new circuit (bottom left). For example, a stop charge switch that switches off the Mac Plus when a battery charger comes on.
 - **Input/Throws** (switch configuration) can be Standby, Bulk, Absorption, Float or Alarm.
 - **State** (circuit load configuration) can be On, Off, Bulk, Absorption or Float.
13. Click **OK** to close the Circuit Load Configuration window
14. Write the configuration to the network to use the new configuration.



For more information, please refer to the CZone® Configuration Tool Instruction manual. Also see chapter 9 for a description of the same settings in MasterAdjust.

11. Trouble shooting

Malfunction	Possible cause	What to do
No output voltage and/or current	No input voltage	Check wiring
	Input voltage too low	Check input voltage, check configuration
	No enable signal on the remote switch input	Check remote switch input
	The primary (input) battery is discharged too far	Charge input battery
LED is red	See chapter 11 for an overview of fault indications of the LED's.	
Output voltage too low, charger supplies maximum current	Load connected to the batteries is larger than battery charger can supply.	Reduce load taken from the batteries.
	Batteries not 100% charged	Measure battery voltage. After some time, this will be higher.
	Wrong setting of the charge voltage	Check settings
Charge current too low	Batteries almost fully charged	Nothing, this is normal when the battery is almost fully charged.
	High ambient temperature	Nothing; if ambient temperature is more than the setting limit, the charge current is automatically reduced.
Batteries not fully charged	Charge current too low	See "Charge current too low" in this table.
	Current to load is too high	Reduce load taken from the batteries.
	Charge time too short	Use a battery charger with higher capacity.
	Battery temperature too low	Use the battery temperature sensor.
	Defective or old battery	Check battery and replace if necessary.
	Wrong setting of the charge voltage	Check settings
Batteries are discharged too fast	Battery capacity reduced due to wastage or sulphation, stagnation	Charge and recharge a few times, this might help. Check battery and replace if necessary.
Batteries are too warm, gassing	Defective battery (short circuit in cell)	Check battery and replace if necessary.
	Battery temperature too high	Use the battery temperature sensor.
	Charge voltage too high	Check settings

Malfunction	Possible cause	What to do
Slow or no MasterBus communication.	Error in the MasterBus wiring.	Check the MasterBus cables.
	No terminating device placed at the ends of the network.	MasterBus needs a terminating device on both ends of the network. Check if connected.
	MasterBus network is configured as a ring network.	Ring networks are not allowed. Check the connections of the network.
Remote panel display shows no Mac Plus	Display is switched off	Switch on display, refer to display manual
	Error in the wiring	Check the network cables
	No terminating device placed at the ends of the network	A network needs a terminating device on both ends of the network, check if available
	Network is configured as a ring network	Ring networks are not allowed. Check the connections of the network.
	Mac Plus is not configured in CZone configuration file	Open CZone Configuration Tool and check.
	Mac Plus Dipswitch incorrect	Open CZone Configuration Tool and check with Force Dipswitch for Address.

12. Technical specifications

	Mac Plus 12/12-50	Mac Plus 12/24-30	Mac Plus 24/12-50	Mac Plus 24/24-30	Mac Plus 24/24-50
Product code	81205105	81205305	81205205	81205405	81205505
Input specifications					
Nominal input voltage	12 V	12 V	24 V	24 V	24 V
Input voltage range	10-16 V	10-16 V	19-32 V	19-32 V	19-32 V
Max input current	50 A	50 A	30 A	30 A	50 A
No load consumption	< 2 mA				
Output specifications					
Nominal output voltage	12 V	24 V	12 V	24 V	24 V
Output voltage range	10-15 V	20-30 V	10-15 V	20-30 V	20-30 V
Max output current	50 A	30 A	50 A	30 A	50 A
Flat battery charge	yes, reduced (25%) charge current at low (<9 V / <18 V) battery voltage				
Protection against overload	yes				
Reverse polarity protection	yes, internally fused, non-replaceable				
Charge characteristic	Mastervolt 3-Step algorithm, Constant voltage (13.25 / 26.5 V)				
Battery types	Flooded, Lithium-Ion, Gel, AGM, User defined				

General specifications

Galvanic isolation	No
Efficiency	> 95% at full output
Ignition protected	Yes, conforming to SAE J1171/ISO 8846
Protection against over-temperature	Yes
Weight	2 kg
Dimensions, hxxwxd	255x165x66 mm (10.0x6.5x5.6 inch)
Cooling	Natural cooling
IP rating	IP23
Connection in- and output	M8 screw terminal, wire size 10 to 50 mm ² [AWG 0 to 8]
MasterBus connectivity	Yes (not powering)
CZone connectivity	Yes
Battery temperature sense	Yes, sensor included
Battery voltage sense	Yes, sensor included

General specifications

Remote switch input	Yes (active high / active low)
DIP switches	Yes, for basic setup
LED	Yes, 3-color LED
Operating temperature range	-20 up to +60 °C, >40 °C derating power [-4 up to +140 °F, >104 °F derating power]
Approvals	CE, E-Mark, SAE J1171 & ISO 8846 Ignition Protected

CZone specifications

LEN (Load Equivalence Number): 0

PGNs (Parameter Group Numbers):

PGN	Description
127506	DC_Detailed_Status (SOC not included)
127507	Charger Status
127508	Battery_Status

Battery settings

Note: the following charge specifications are based on Mastervolt batteries. Specifications for a given chemistry of a different manufacturer may vary. If connecting batteries of a different manufacturer, make sure the manufacturer's recommendations are met. Select *User defined* to be able to adjust the battery settings in either MasterAdjust or in the CZone Configuration Tool.

Charging specifications	Battery type		
	Flooded (default)	Gel / AGM	Lithium-Ion
Bulk voltage	14.25 V*	14.25 V*	14.25 V*
Max bulk time	480 min	480 min	480 min
Min bulk time	120 s	120 s	120 s
Start bulk time	13.25 V*	13.25 V*	13.25 V*
Return to bulk voltage	12.80 V*	12.80 V*	13.25 V*
Return to bulk time	30 s	30 s	240 s
Abs. voltage	14.25 V*	14.25 V*	14.25 V*
Max absorp. time	240 min	240 min	240 min
Min absorp. time	15 min	15 min	15 min
Return amps(battery full current)	6.0 % I _{MAX}	6.0 % I _{MAX}	6.0 % I _{MAX}
Float voltage	13.25 V*	13.80 V*	13.50 V*

* For a 24 V battery charger, multiply the voltages by two.

Characteristics

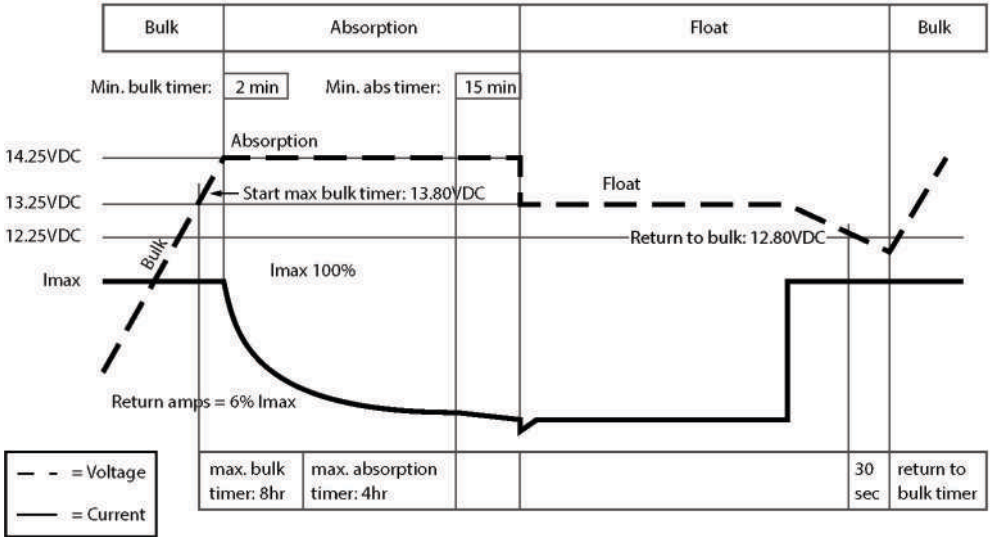

Figure 2. Typical charge characteristic (at 25°C / 77°F).
 For a 24 V battery charger, multiply the voltages by two.



Europe, Middle East & Africa

Technical Support

T: +31 (0) 20 34 22 100

E: ts.emea@OneASG.com

Location & Shipping

Navico Group EMEA

Snijdersbergweg 93

1105 AN Amsterdam

The Netherlands

Americas & Caribbean

Technical Support

T: +1 262 293 0600 / 800 307 6702

E: tech.mastervolt@OneASG.com

Location & Shipping

Navico Group US

N85 W12545 Westbrook Crossing

Menomonee Falls, WI 53051

United States

Asia Pacific

Technical Support

T: +64 9 415 7261

E: technical.apac@OneASG.com

Location & Shipping

Navico Group APAC

42 Apollo Drive

Rosedale, Auckland 0632

New Zealand

Document version: 10000021042/02 (September 23)

Copyright ©2023 Navico Group EMEA B.V. All rights reserved.