

Installation and maintenance manual

SINGLE LEVER CONTROL

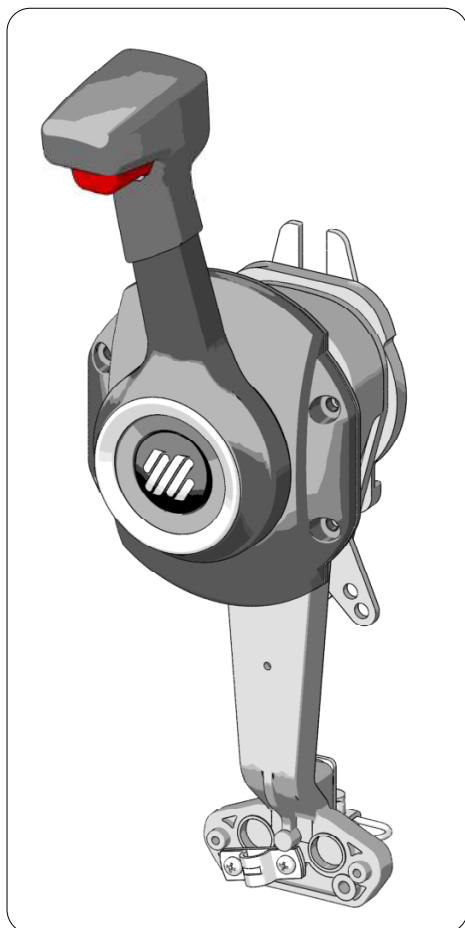

B110B
B110W

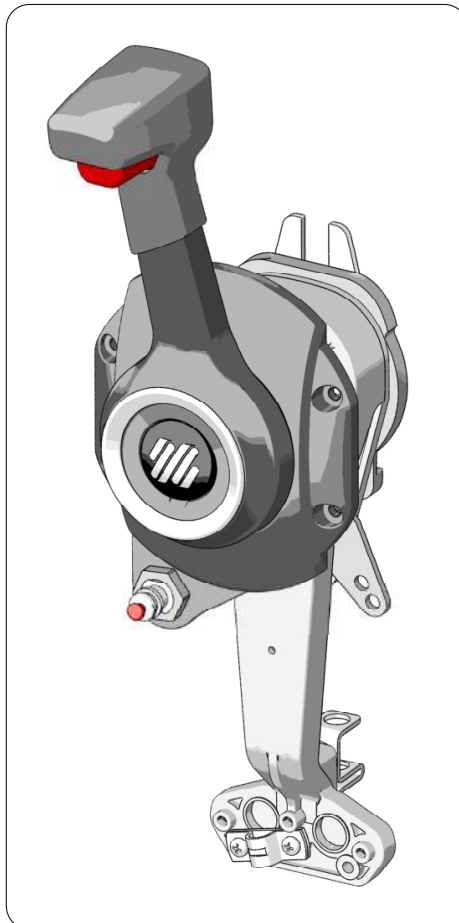

B110B/KS
B110W/KS

ENGLISH

ITALIANO

FRANÇAIS



ULTRAFLEX

CE

UK
page 2

I
pag. 23

F
page 45



ULTRAFLEX

Dear Customer,

We would like to thank you for choosing an **ULTRAFLEX** product.

ULTRAFLEX has been a leader in steering systems for pleasure and professional boats for many years. **ULTRAFLEX** production is since ever synonymous of reliability and safety.

All **ULTRAFLEX** products are designed and manufactured to ensure the best performance. To ensure your safety and to maintain a high quality level, **ULTRAFLEX** products are guaranteed only if they are used with original spare parts.

ULTRAFLEX and **UFLEX** Quality Management Systems are certified by the Det Norske Veritas - Germanischer Lloyd (DNV-GL), in conformity with the UNI ES ISO 9001:2015 rule.

The quality management system involves all the company resources and processes starting from the design, in order to:

- ensure product quality to the customer;
- maintain and improve the quality standards constantly;
- pursue a continuous process improvement to meet the market needs and to increase the customer satisfaction.

ULTRAFLEX Environmental Management System is certified by the Det Norske Veritas - Germanischer Lloyd (DNV-GL), in conformity with the UNI EN ISO 14001:2015 rule.

Products for pleasure boats are constantly tested to check their conformity with the 2013/53/EU directive.



"**ULTRAFLEX** has over 85 years of experience in the marine industry and is a world leader in the production of mechanical, hydraulic and electronic steering systems, control boxes and steering wheels for any kind of pleasure, fishing or commercial boats.

The key factors which explain the increasing success of our products all over the world are the reliability of our products and the before and after sale service, the quality of the company organization and of the human resources and the continuous spending in research and development".

ULTRAFLEX S.p.A.

16015 Casella (Genova) Italia - Via Crose, 2

TABLE OF CONTENTS 

USE OF THE MANUAL AND SYMBOLS USED 4
 INFORMATION LETTER 5
 WARRANTY 5

SECTION 1 - PRODUCT DESCRIPTION 

1.1 PRODUCT DESCRIPTION AND RECOMMENDED USE 6
 1.2 DIMENSIONS 7

SECTION 2 - TRANSPORT 

2.1 GENERAL WARNINGS 8
 2.2 PACKAGING CONTENTS 8

SECTION 3 - INSTALLATION 

3.1 NECESSARY TOOLS 10
 3.2 CONTROL BOX INSTALLATION 10
 3.2.1 LEVER WITHOUT KILL SWITCH MODEL 11
 3.2.2 LEVER WITH KILL SWITCH MODEL 12
 3.3 KILL SWITCH ELECTRIC CONNECTION 13
 3.4 NEUTRAL SAFETY SWITCH INSTALLATION(OPTIONAL) 14
 3.5 NEUTRAL SAFETY SWITCH + TILT INSTALLATION (OPTIONAL) 15
 3.6 SHIFT CABLE INSTALLATION 16
 3.6.1 SHIFT CABLE CONNECTION TO FRAME 16
 3.6.2 SHIFT CABLE CONNECTION TO ROCKER ARM 17
 3.7 THROTTLE CABLE INSTALLATION 18
 3.7.1 THROTTLE CABLE CONNECTION TO ROCKER ARM 18
 3.8 LEVER UNIT ASSEMBLY 19
 3.9 CLUTCH ADJUSTMENT SCREW 19
 3.10 INSTALLATION OF THE TRIM CABLES 19

SECTION 4 - LEVER USE 

4.1 LEVER USE 20
 4.2 NEUTRAL WARM-UP 20
 4.3 TRIM OPERATION 20

SECTION 5 - SAFETY WARNINGS 

5.1 SAFETY WARNINGS DURING INSTALLATION AND USE 21
 5.2 CLOTHES 21

SECTION 6 - MAINTENANCE 

6.1 ORDINARY MAINTENANCE 21
 6.2 EXTRAORDINARY MAINTENANCE 22

SECTION 7 - DISMANTLING 

7.1 DISMANTLING 22

USE OF THE MANUAL AND SYMBOLS USED

THE INSTALLATION AND MAINTENANCE MANUAL is the document accompanying the product from its sale to its replacement and discharge. The manual is an important part of the product itself. It is necessary to read carefully the manual, before carrying out ANY ACTIVITY including the product handling and unloading.

In this manual the following symbols are used to ensure the user safety and to guarantee the correct operation of the product:

⚠ DANGER



Immediate hazards which CAUSE severe personal injury or death.

⚠ WARNING



Denotes that a hazard exists which can result in injury or death if proper precautions are not taken.

⚠ CAUTION



Denotes a reminder of safety practices or directs attention to unsafe practices which could result in personal injury or damage to the craft or components or to the environment.

NOTICE



Important information for the correct installation and for maintenance, that does not cause any damage.



Operations which should be performed by qualified or specialized personnel to avoid risks are identified by the symbol shown here. Provide the personnel who will be installing the product with appropriate training and make sure that they understand and implement the instructions provided.

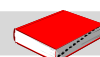
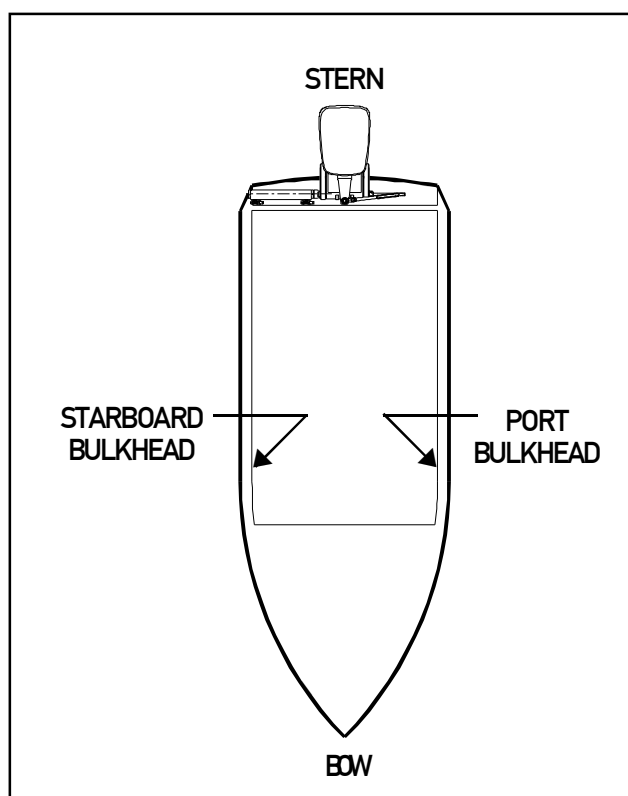

INFORMATION LETTER

This installation and maintenance manual represents an important part of the product and must be available to the people in charge of its use and maintenance.

The user must know the content of this manual.

ULTRAFLEX declines all responsibility for possible mistakes in this manual due to printing errors.

Apart from the essential features of the described product, **ULTRAFLEX** reserves the right to make those modifications, such as descriptions, details and illustrations, that are considered to be suitable for its improvement, or for design or sales requirements, at any moment and without being obliged to update this publication.

ALL RIGHTS ARE RESERVED. Publishing rights, trademarks, part numbers and photographs of **ULTRAFLEX** products contained in this manual are **ULTRAFLEX** property.

Great care has been taken in collecting and checking the documentation contained in this manual to make it as complete and comprehensible as possible. Nothing contained in this manual can be interpreted as warranty either expressed or implied - including, not in a restricted way, the suitability warranty for any special purpose. Nothing contained in this manual can be interpreted as a modification or confirmation of the terms of any purchase contract.

WARNING

To ensure the correct product and component operation, the product must be installed by qualified staff. In case of part damage or malfunction, please contact the qualified staff or our Technical Assistance Service.

TECHNICAL ASSISTANCE SERVICE

UFLEX S.r.l.

Via Milite Ignoto,8A
16012 Busalla (GE)-Italy
Tel: +39.010.962.01
Email: service@ultraflexgroup.it
www.ultraflexgroup.it

North - South - Central America:

UFLEX USA

6442 Parkland Drive
Sarasota, FL 34243
Tel: +1.941.351.2628
Email: sales@uflexusa.com
www.uflexusa.com

WARRANTY

ULTRAFLEX warrants that its products are built according to the standards of good workmanship and are free of defects in materials and workmanship.

This warranty is valid for two years starting on the date of manufacture with the exception of cases in which products are installed and used on working vessels or on vessels commercial use, in which case the guarantee is limited to 1 year from the date of manufacture.

This warranty is limited to free replacement or repair of the item, which must be returned carriage paid, provided we find it to be effectively defective in materials and/or workmanship.

The warranty does not cover any direct or indirect damages. The warranty specifically does not cover, and we shall not be liable for (except for replacement or repair of defective items under the terms and conditions set forth above), malfunctioning of our products if their failure or poor functioning is attributable to incorrect installation or to negligent or improper use.

This warranty does not cover products installed on racing boats or used in a competitive context. The descriptions and illustrations in this manual are indicative only.

Please contact our Assistance Service for more detailed information.

The components of **ULTRAFLEX** steering and control systems are marked  as required by the Directive 2013/53 EU. Note that the **ULTRAFLEX** warranty shall be automatically forfeited if any **ULTRAFLEX** components are installed in a steering and control system along with products of other brands.



1 PRODUCT DESCRIPTION

1.1 Product description and recommended use

The single lever control must be assembled on the side of the control console of the boat. The lever is provided with warm-up gas button device and switch button to adjust the trim with shift gear in neutral position.

The **B110** single control lever is also equipped with a standard kit to use the lever with the following **ULTRAFLEX** cables:

- **C2 - C8 - MACHZero** (type 33C cables);

If the Customer mounts the lever on engines that require the use of cables other than those mentioned above, a specific kit (optional) must be used for their installation as indicated below:

KIT K74: C5 and MACH5 cables (Mercury® GEN I)

KIT K75: C36 and MACH36 cables (Mercury® GEN II)

KIT K76: C14 cable (OMC®, EVINRUDE®)

In this case, do not use the standard kit supplied.

⚠ CAUTION

If you use an optional kit, follow the instructions provided with it.

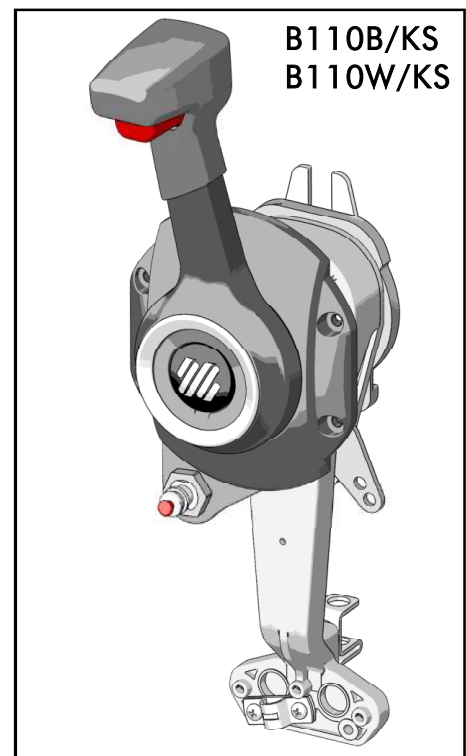
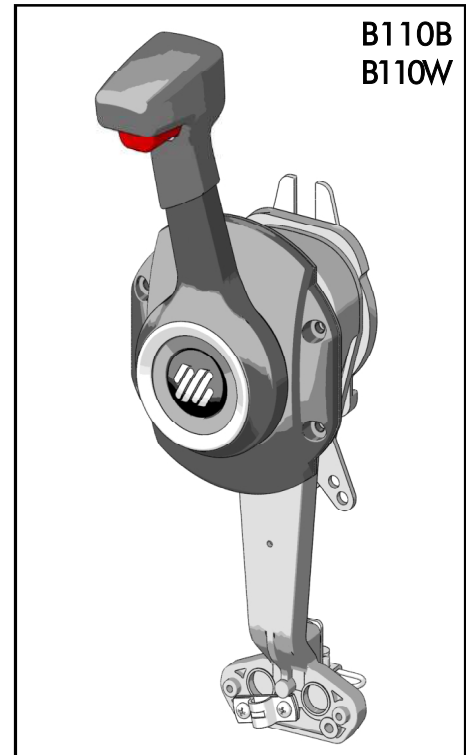

1.2 Dimensions

The drawings below show the dimensions of the four B110 single lever control models.

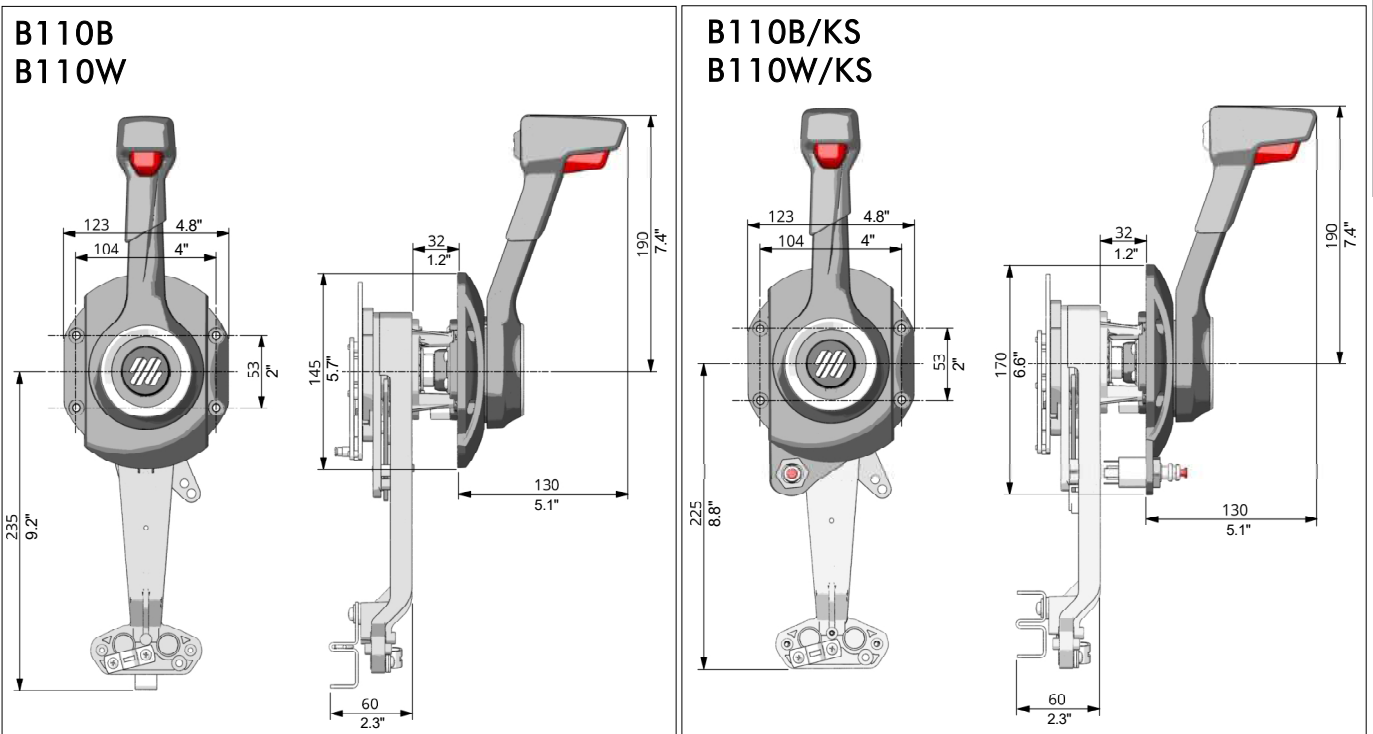

MINIMUM OVERALL DIMENSIONS FOR THE LEVER ROTATION

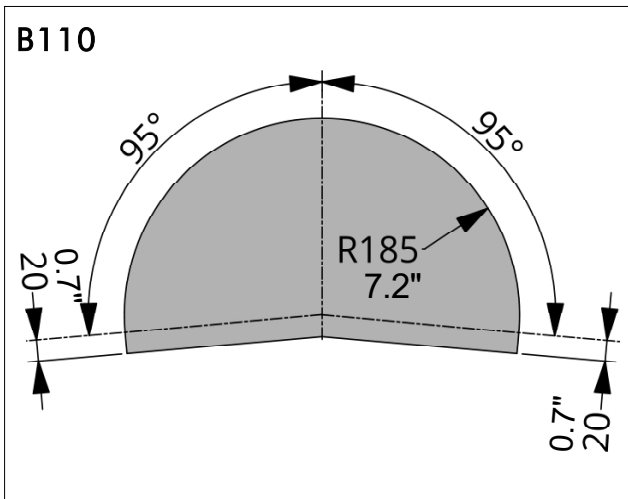

NOTICE

Make sure that the lever can rotate freely and its stroke is not prevented by obstacles.



2 TRANSPORT

2.1 General warnings

The product weight with its packaging is 2.5kg (5.5 pounds) and so it can be handled manually.

⚠ WARNING

The staff in charge of handling must operate with protective gloves and safety shoes.

2.2 Packaging contents

Before using the equipment check that the product has not been damaged during transport. Also make sure that all the standard components are in the packaging (see list).

In case of damage, notify the claim to the forwarder and inform the supplier.

Contents of the control box packaging:

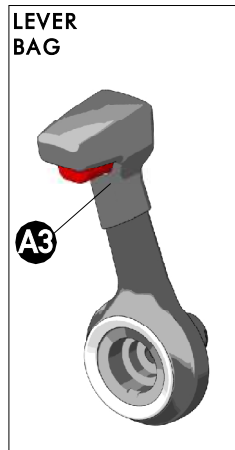
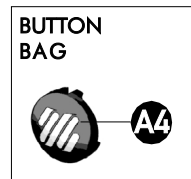
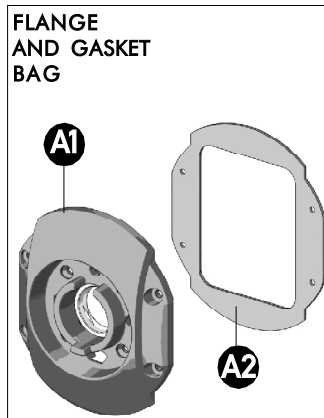
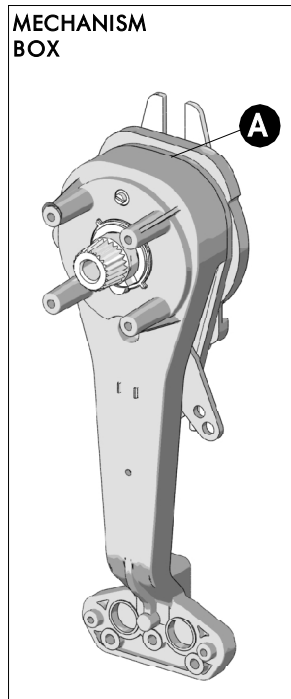

REF	COMPONENT
A	control box
A1	flange
A2	gasket
A3	lever
A4	button

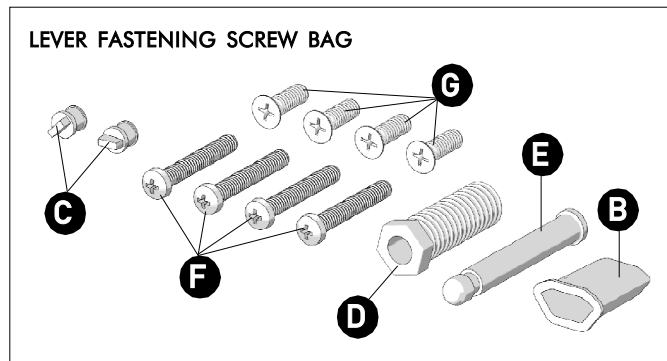

REF	COMPONENT
B	rubber wires protection
C	plugs
D	lever fastening screw
E	pin
F	flange fastening screw
G	mechanism fastening screw



BAG OF SMALL PARTS FOR C2 - C8 MACHZero CABLES

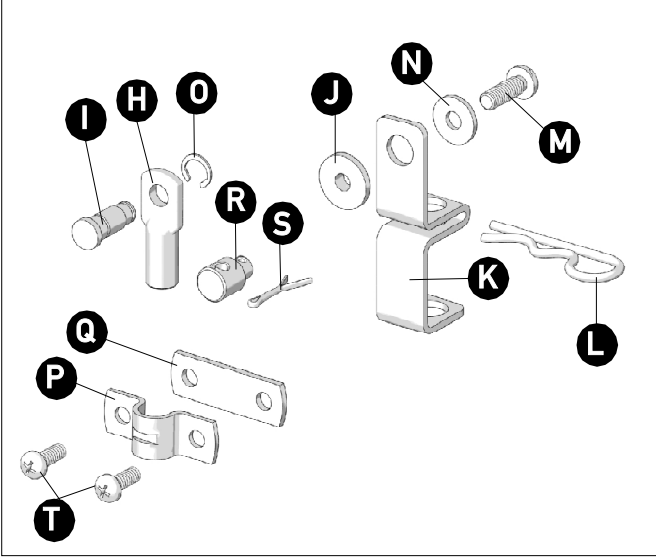

REF	COMPONENT
H	cable end fitting
I	cable tie pin
J	casing fastener bushing
K	casing fastener block
L	elastic split pin
M	screw
N	washer
O	circlip
P	u bracket
Q	bracket
R	cable terminal
S	split pin
T	screws

If the lever is equipped with kill switch (B110B/KS and B110W/KS models), an additional kit shall be supplied (in addition to the kits described in the previous page) composed of the lanyard with fastening clip, the nut and the switch itself.

These components shall be supplied in the same bag.

COMPONENTS FOR LEVER WITH KILL SWITCH BAG

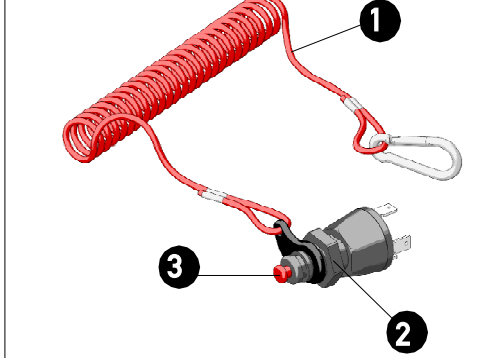

REF	COMPONENT
1	lanyard with fastening clip
2	nut
3	kill switch

NOTICE

For a correct installation of the kill switch, please refer to paragraph 3.2.2.

CAUTION

Packaging must be disposed of in accordance with the current legal directives.



3 INSTALLATION

3.1 Necessary tools

ENGLISH



Phillips screwdriver (Ø6)



Flathead screwdriver (Ø2)



Pliers



14 mm socket spanner



Drill

3.2 Control box installation



NOTICE

Depending on the control cables, it is possible to mount the mechanism in horizontal or vertical position as shown in the figures on the side, by rotating the internal mechanism in such a way that the flange inspection hole matches with the clutch adjustment screw of the mechanism (see paragraph 3.9). This consideration is also valid for lever with kill switches models.

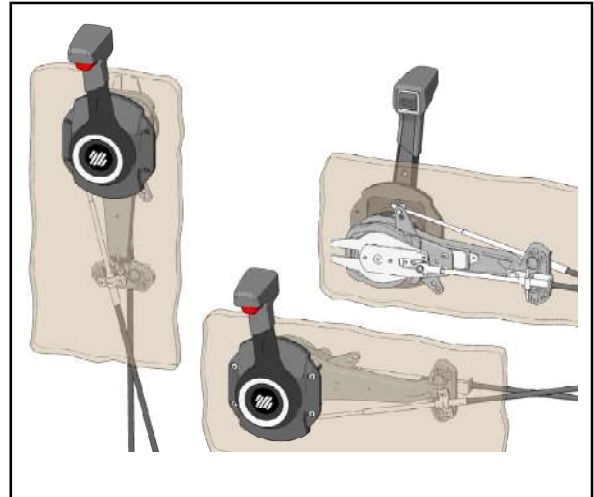

CAUTION

Use the "C" plugs supplied in the screw bag to close two of the three not used inspection holes in the flange. This is also valid for lever models with kill switches.

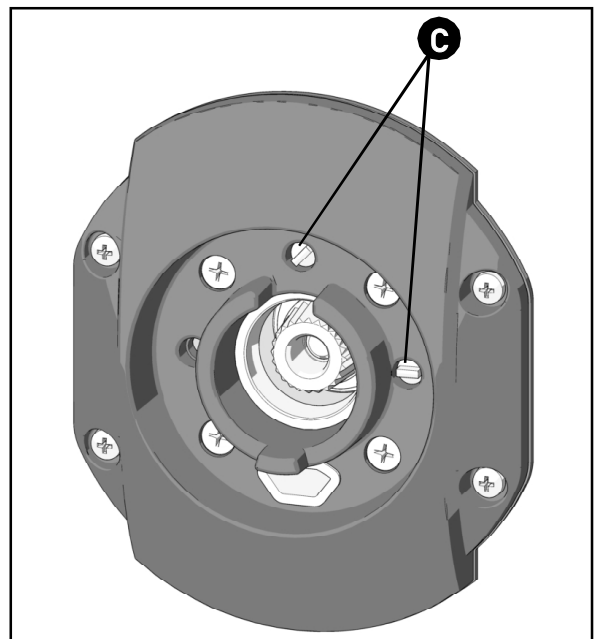

3.2.1 Lever without kill switch model

⚠ CAUTION

Avoid bending the cables too narrowly (minimum radius: 200 mm - 8"). The use of **ULTRAFLEX** cables is recommended.

1 Refer to the dimensions indicated in paragraph 1.2 to verify that the control can actually be installed in the chosen position.

2 After having established the appropriate location, drill the necessary holes to insert the mechanism with the help of the appropriate template (supplied). The thickness of the lever installation surface must not exceed 20mm (0.7").

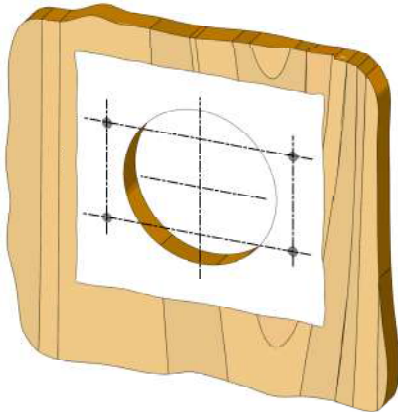

3 Fasten the flange (A1) and its gasket (A2) by means of screws (F).

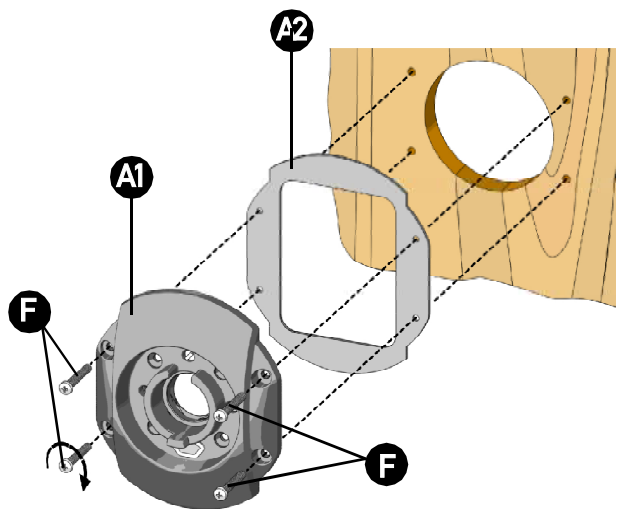

4 Fasten mechanism (A) to flange (A1) by means of screws (G).

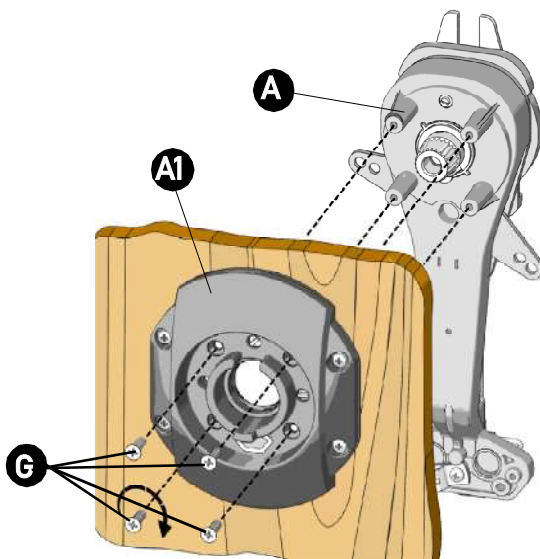

NOTICE

Then, connect the throttle cable and the shift cable to the frame and the rocker arm, as indicated in paragraphs 3.6 and 3.7.



3.2.2 Lever with kill switch model

⚠ CAUTION

Avoid bending the cables too narrowly (minimum radius: 200 mm - 8"). The use of **ULTRAFLEX** cables is recommended.

1 Refer to the dimensions indicated in paragraph 1.2 to verify that the box can actually be installed in the chosen position.

2 After having established the appropriate location, drill the necessary holes to insert the mechanism with the help of the appropriate template (supplied). The thickness of the lever installation surface must not exceed 20mm (0.7").

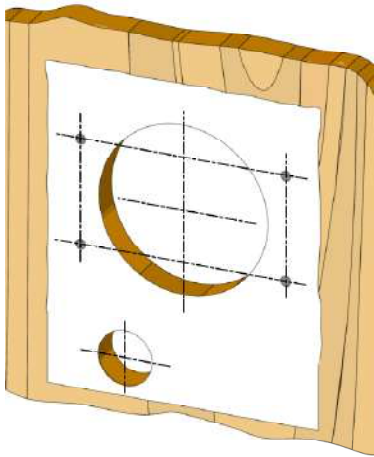

3 Screw switch (1) to the unit made up of flange (A1) and gasket (A2) by means of nut (2).

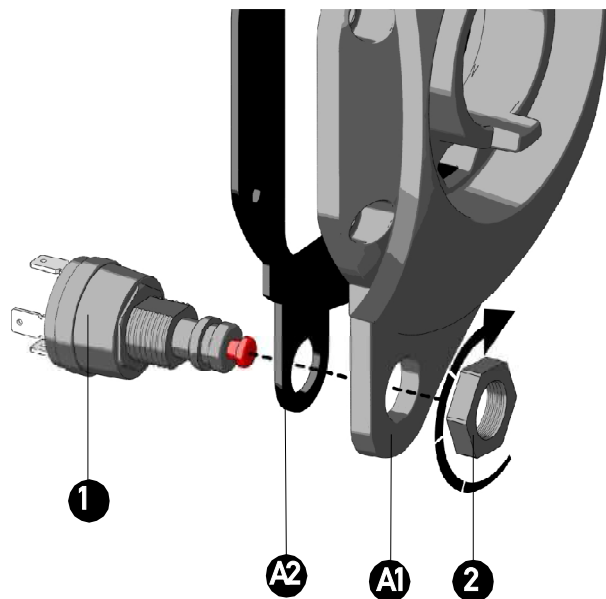

4 Fasten the flange (A1) and its gasket (A2) by means of screws (F).

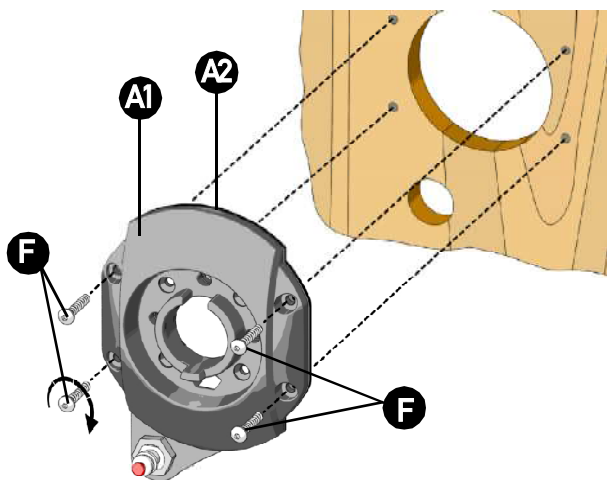

5 Fasten mechanism (A) to flange (A1) by means of screws (G).

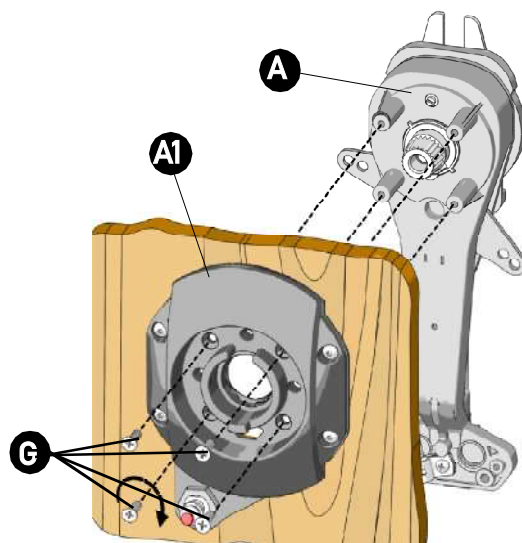

3.3 Kill switch electrical connection



⚠ WARNING

For a proper switch connection, please refer to the generic wiring diagram below. In any case, the user must make the connections considering the type of electrical system present on his/her boat.

⚠ WARNING

The switch incorrect installation can cause serious or even fatal physical injury.

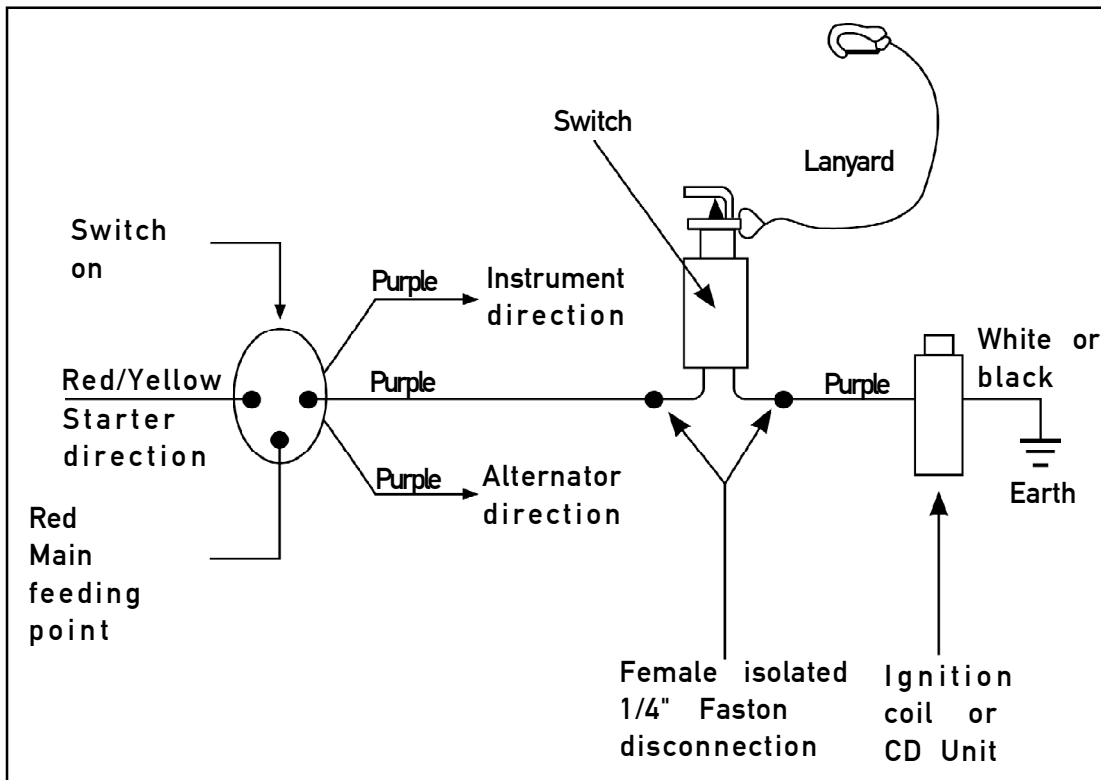

The switch is equipped with a clip with a lanyard that maintains the switch in position to ensure the engine to be powered. The lanyard, by means of the clip, is connected to the operator safely. If the operator moves away from the central console, the clip disconnects by releasing the piston and stopping the engine.

For proper operation of the kill switch, perform the following operations:

- 1) before the engine is switched on, check that the clip is correctly positioned on the switch and can rotate freely.
- 2) check the condition of the lanyard: if this was cut, worn or frayed, replace it.
- 3) start the engine.
- 4) test the switch by disconnecting the fastening clip of the lanyard from the same: the engine must stop

⚠ WARNING

If the engine does not stop, check the entire wiring.

If the engine does not start, does not stop or starts again with the lanyard clip disconnected, contact your local boat dealer for assistance.

⚠ WARNING

It is forbidden to change the length of the lanyard or use the lanyard provided by another manufacturer with this switch; this may compromise its correct functionality.

Incorrect use, unauthorised modification or incorrect installation of this safety device may cause serious or even fatal physical injury.



3.4 Neutral safety switch installation (optional)



This optional device allows starting the engine only with the shift gear in "neutral" position, preventing the boat from moving in a wrong way. To assemble it, follow the instructions below:

Secure the safety switch X41 by means of screws (1), washer (2) and nut (3) (supplied in X41 kit), as shown in the picture.

NOTICE

Keep the screw head on the switch surface.

For the correct operation of neutral safety switch X41, proceed as follows:

- 1) before the engine is started, verify that the switch is installed correctly.
- 2) move the lever back and forth (from the NEUTRAL position) and check that the device switches.
- 3) wire the switch paying particular attention to electrical diagrams and connections.
- 4) start the engine and verify that the system works properly.

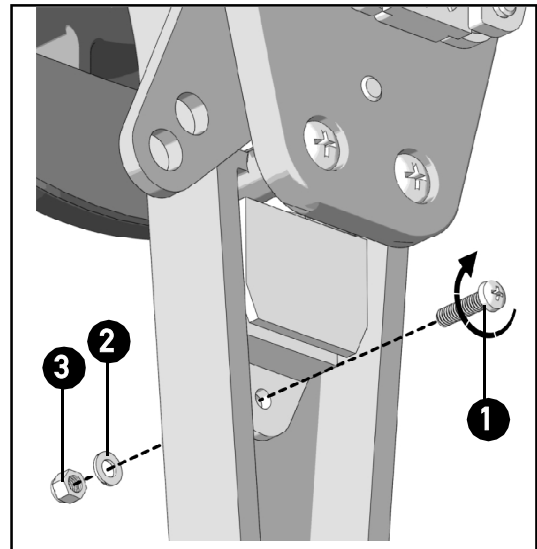
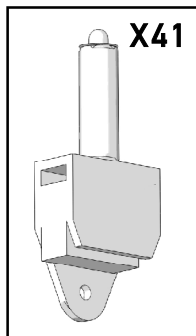

⚠ CAUTION

When the lever is in NEUTRAL position, the circuit must be closed; when it is in a different position, it must be open.

⚠ WARNING

If the engine switches on when the lever is not in NEUTRAL position, check the entire wiring. Misuse, unauthorized modifications, or incorrect installation of this neutral safety device can cause serious or even fatal physical injury.



3.5 Neutral safety switch + tilt installation (optional)



This device (optional) allows the start of the engine only with the lever in the position "neutral", preventing the boat from moving in a wrong way and at the same time, by using the switch on the lever, it allows to control the tilt of the engine.

To assembly, proceed as follows:

Secure the X48 safety switch with screw (1), washer (2) and nut (3) (included in the X48 kit), as shown in the picture.

NOTICE

Keep the screw head on the switch surface.

For the correct operation of the X48 safety switch, proceed as follows:

- 1) before starting the engine, check that the switch is installed correctly.
- 2) move the lever back and forth (from the NEUTRAL position) and check that the device switches.
- 3) wire the switch paying particular attention to electrical diagrams and connections.
- 4) start the engine and verify that the system works properly.

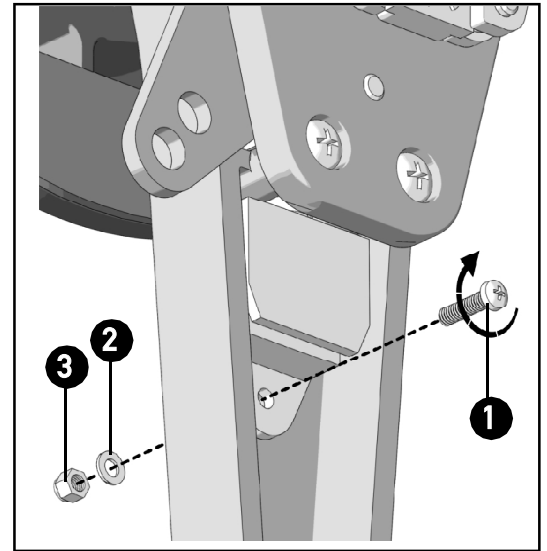
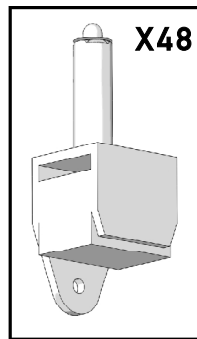

CAUTION

When the lever is in NEUTRAL position, both circuits must be closed; when it is in a different position, the circuits must be open.

WARNING

If the engine switches on when the lever is not in NEUTRAL position, check the entire wiring. Misuse, unauthorized modifications, or incorrect installation of this neutral safety device can cause serious or even fatal physical injury.



3.6 Shift cable installation



CAUTION

Before starting the installation, make sure the rocker arm is in neutral position (horizontal) and the throttle in idle position (as shown in the picture).

Identify on which side of the frame the shift cable will be installed depending on whether the user needs a movement to pull or push the cable.

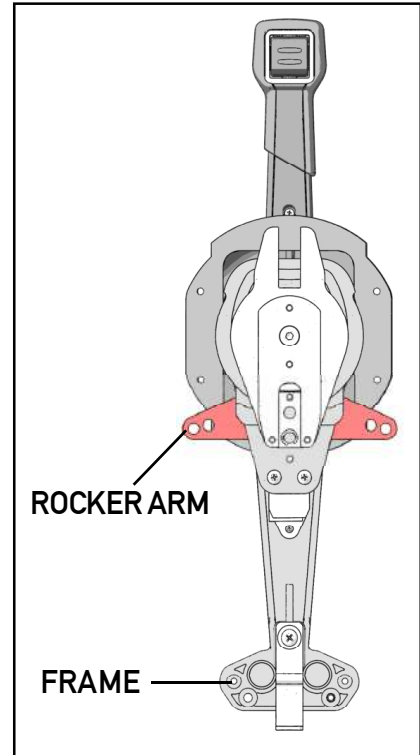

3.6.1 Shift cable connection to the frame

- 1 Connect the end conduit fitting of the shift cable to the frame by means of bracket (Q) and U-bracket (P) by means of screws (T). then fasten the screws.

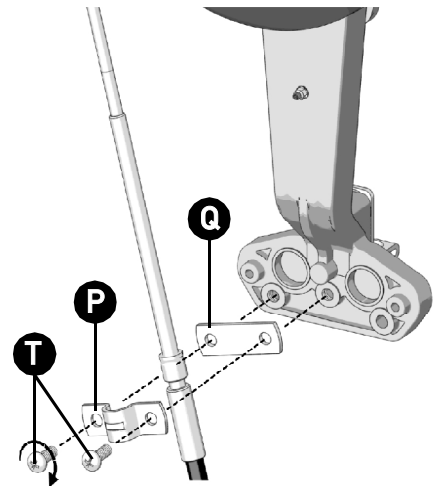

3.6.2 Shift cable connection to rocker arm

1 Screw terminal(R) on the thread of the shift cable.

Close or extend the cable to insert the cablehead in the hole of the rocker arm. Check that the length of the cable is correct. If it is correct, fasten locknut (1) and insert the appropriate split pin (S) in the terminal of the cable to prevent its release from the rocker arm. If the length is not correct, screw or unscrew the terminal on the thread of the cable to obtain a finer adjustment, then tighten the locknut (1) and insert the appropriate split pin (S) into the cable terminal.

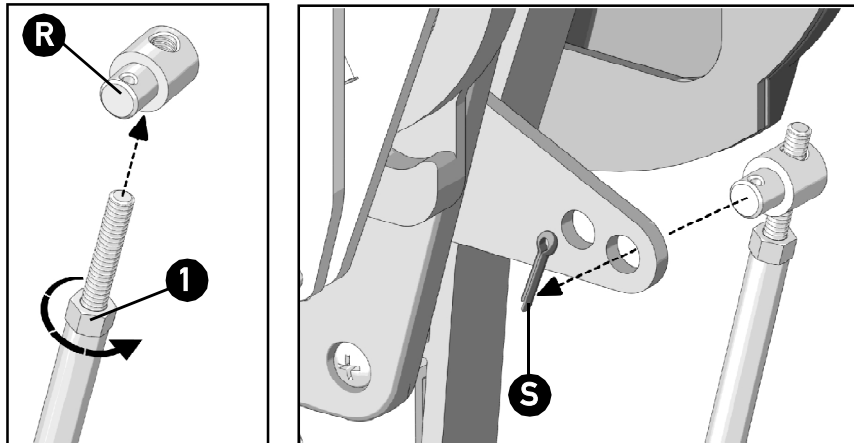

⚠ CAUTION

- The correct operation of the control depends on the precise regulation of the length of the shift cable.

⚠ CAUTION

In no case shall the stroke developed by the single lever control (67 mm (2.64") on the inner hole; 78 mm (3.0") on the outer hole of the rocker arm) exceeds the stroke measured on the engine lever. This could damage both the cable and the control.

- The conduit of the cables, which appears from the lower part of the control, may be group-wrapped or fixed at a minimum distance of 500 mm (19.7") from the control itself.



3.7 Throttle cable installation



The instructions for connecting the throttle cable are provided below.

ENGLISH

1 Rotate the lever at least 45° to bring the slide in the lower part of the rocker arm to insert the pin (see picture). Insert pin (I) in the outer hole of the slide from the lower part of the rocker arm towards the upper (see picture) and lock it by means of circlip (O).

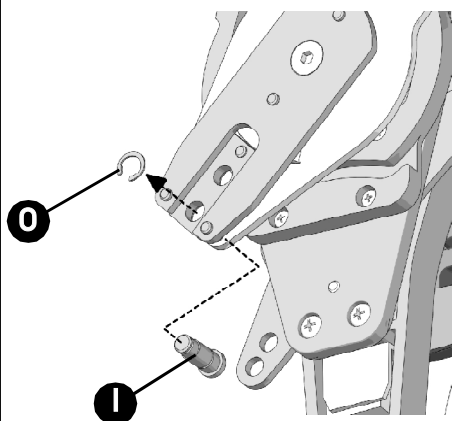

2 Secure casing fastener block (K) to the mechanism by means of the casing fastener bush (J), washer (N) and screw (M). Insert the cable in the casing fastener (K), making sure it is turned outwards, as indicated in the picture. Stop it by inserting the elastic split pin (L) into the center seat.

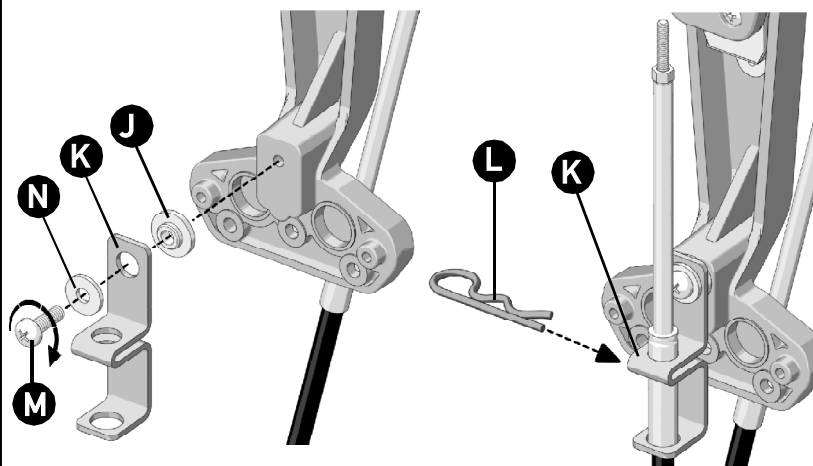

3.7.1 Throttle cable connection to rocker arm

1 Screw cable and fitting (H) on the thread of the throttle cable.

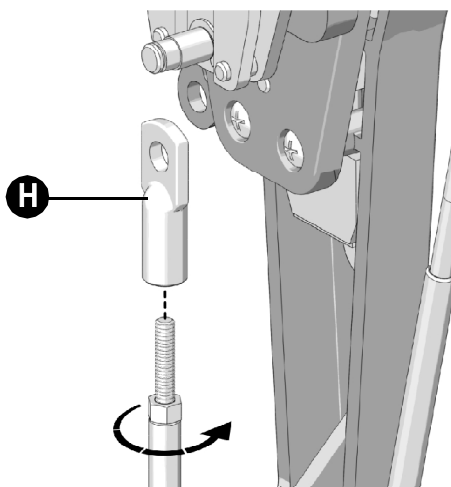

2 Insert the cable and fitting on pin (I) and secure it by means of circlip (O).

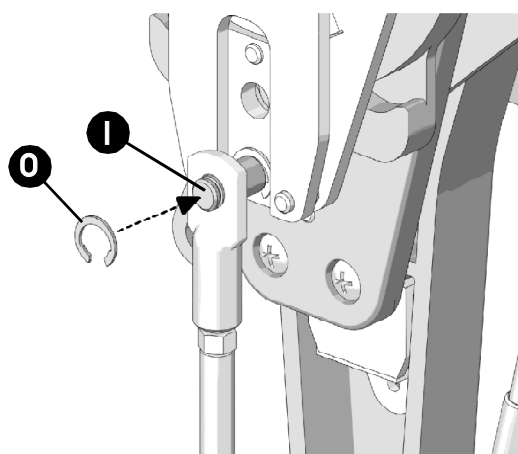

⚠ CAUTION

- The correct operation of the control depends on the exact adjustment of the throttle stroke.



3.8 Installation of the lever unit



1 Place the rubber wires protection (B) in the hole at the bottom of flange (A1) and insert the wires of the trim, which come out from the lever (A3), through it. Insert the lever in neutral position (vertical) in the control box on the splined shaft by guiding the cables towards the mechanism. Insert screw (D) equipped with pin (E) and screw it by means of a 14 mm wrench. Then, insert button (A4) in its seat on the lever hub by pushing it until you hear a click. This procedure shall also apply to lever models with kill switch.

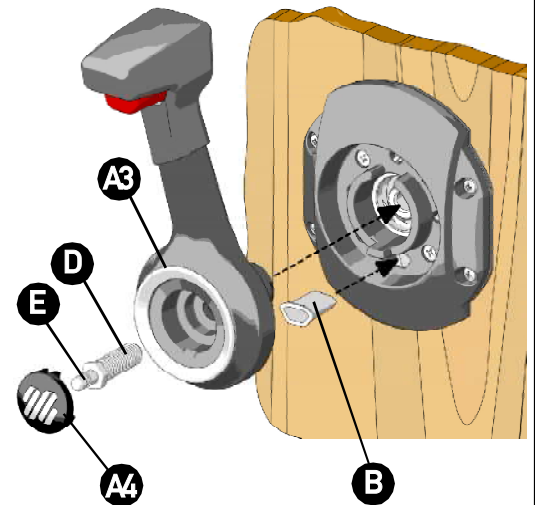

⚠ CAUTION

Install the rubber cable shaft, it protects the cables from any damage.

3.9 Clutch adjustment screw



1 Gain access to the clutch adjustment screw by means of a flathead screwdriver. Turn the screw clockwise to increase the clutch, counterclockwise to decrease it.

NOTICE

THE LEVER CLUTCH ADJUSTMENT MUST ALWAYS BE CARRIED OUT WITH THE ENGINE OFF. THE LEVER MUST BE REMOVED FROM THE FLANGE.

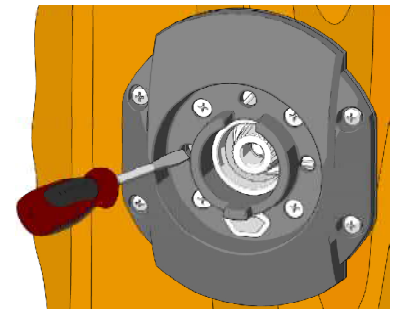

3.10 Installation of the trim cables



The TRIMs allow the position of the motors to be changed by moving them up or down. The diagram aside shows how to connect the three wires green (engine up), red (common) and white (engine down).

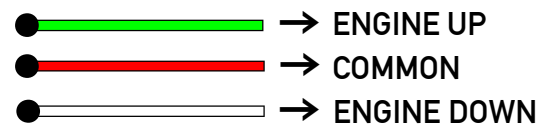

NOTICE

For correct operation of the TRIM, carry out the following operations:

- 1) Before the engine is switched on, check that the electrical cables of the TRIM have been correctly clamped near the foot of the mechanism (making sure that they are not too tight, leaving sufficient length).
- 2) Wire the TRIM paying particular attention to the wiring diagrams and connections.
- 3) Power the unit and check that the system is working correctly.

⚠ WARNING

Do not modify this switch in any way, as this may impair its proper functioning. Incorrect use, unauthorised modifications or improper installation of this safety device may result in serious injury or even death to persons.

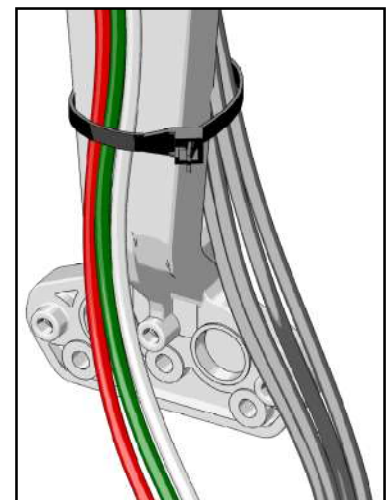

4 LEVER USE

4.1 Lever use

The lever is kept in a neutral position (vertical); to unlock it, press the trigger placed under the handle. The lever stroke is divided into two movements: in the first phase, 30°, the shift gear is activated. In the second, 65°, the throttle is activated. By moving the lever forward the boat advances, while backwards it proceeds in reverse.

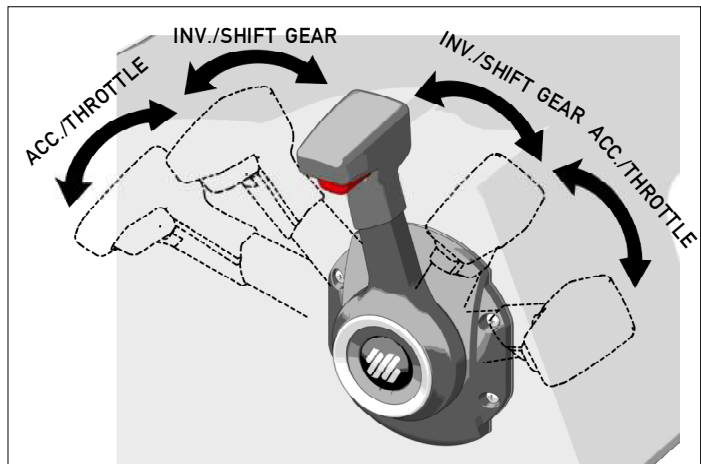

⚠ DANGER

If the control has no neutral safety switch, before starting the engine make sure that it is in neutral position.



4.2 Neutral warm-up

Push the central button and, by keeping it pressed, rotate the lever clockwise or counterclockwise, to warm-up the engine without moving the boat.

As you return to neutral position, the return spring will bring the button to initial position.

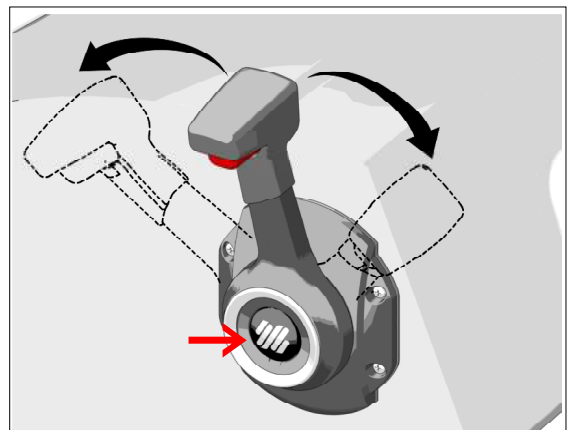

4.3 Trim operation

The trim allows to adjust the tilt of the engines.

⚠ WARNING

If the user has purchased the neutral safety switch + tilt optional (X48 kit), it is necessary to consult the installation and operating instructions referred to in paragraph 3.5.

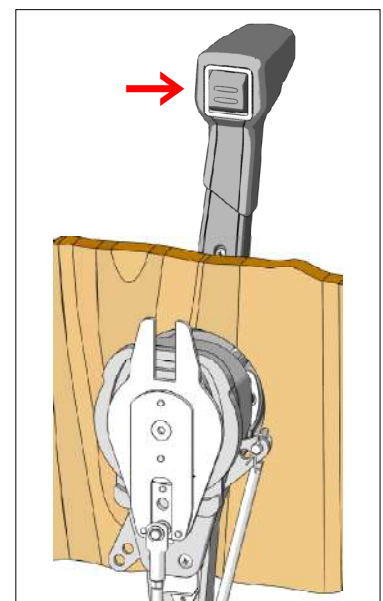

5 SAFETY WARNINGS

This section shows the safety rules which must be followed for the correct equipment operation. We recommend reading carefully this section and also the other manuals supplied with the other components of the single lever control.

5.1 Safety rules during installation and use

RESPECT STRICTLY the following safety rules:

ULTRAFLEX declines all responsibility in case the user does not follow these rules and it is not responsible for negligence during the use of the system.

DANGER

- **DO NOT PUT HANDS BETWEEN THE MOVING PARTS.**
- Do not disable the safety devices.
- Do not modify or add devices to the system, without **ULTRAFLEX** written authorisation or technical intervention which will prove the modification.
- Do not use the equipment for a purpose different from the one it has been designed for, which is specified in the installation and maintenance manual.
- Do not let non-specialized staff perform the installation.

WARNING

- During the system installation, clean carefully to prevent foreign matters from entering the system. Even a little object may cause lasting damage that is not detected immediately.
- Avoid too narrow bend radius of cables <200 mm (8").
- Avoid the cable contact with edges or sharp corners.
- Avoid the cable contact with heat sources.

5.2 Clothes

WARNING

During installation, inspection or maintenance,

IT IS STRICTLY FORBIDDEN to wear necklaces, bracelets or clothes which could get caught in the moving parts.

6 MAINTENANCE

6.1 Ordinary maintenance

WARNING

Poor installation and maintenance may result in loss of steering and cause property damage and/or personal injury.

Maintenance requirements change according to climate, frequency and the use. Inspections are necessary at least every year and must be carried out by specialized marine mechanics. Carry out the following maintenance operations:

- Periodically wash the components with soft water by removing any salt deposit.
- Every month check and if necessary tighten all the nuts fastening the system.

⚠ DANGER

If the check nuts are removed or disassembled, this could cause the single lever control malfunction as well as damage to people or things.

- Periodically check the absence of corrosion on the metal parts of the cable terminals and of abrasions on the sheath.
- Replace the damaged parts that can compromise the single lever control integrity.

ENGLISH

6.2 Extraordinary maintenance

Technical assistance

For any information or for assistance with unusual applications please contact our technical support personnel (See paragraph "Information letter").

7 DISMANTLING

7.1 Dismantling

When for any reason, the system is put out of service, it is necessary to follow some rules in order to respect the environment.

Sheaths, pipelines, plastic or non-metallic components must be disassembled and disposed of separately.

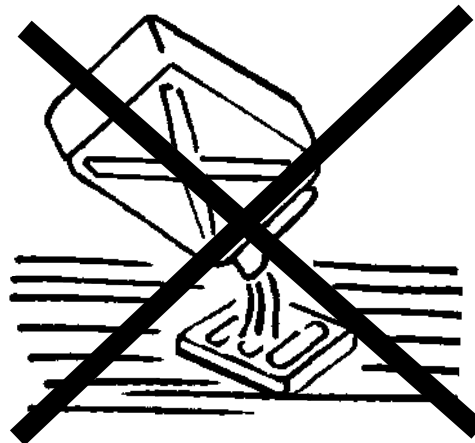

Manuale di installazione e manutenzione

COMANDO MONOLEVA

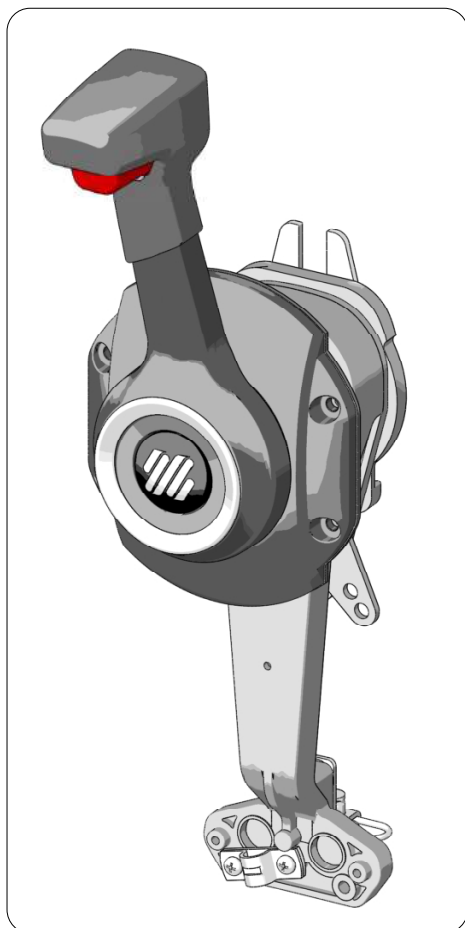

B110B
B110W

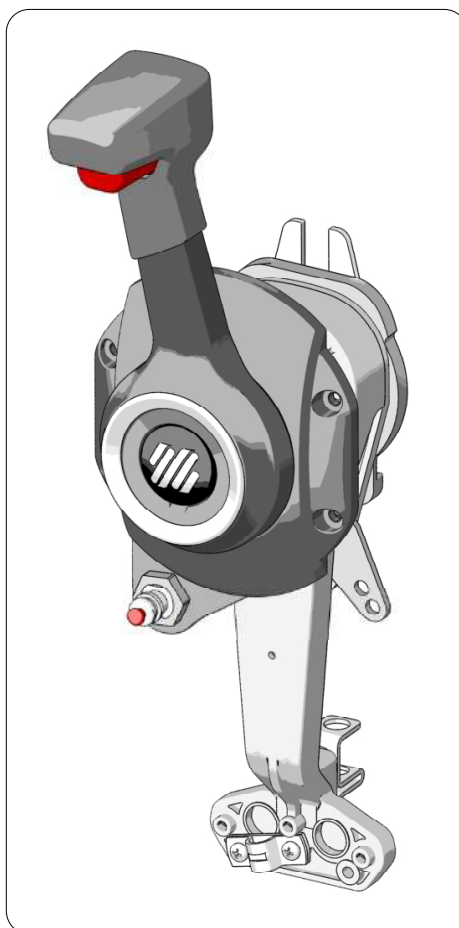

B110B/KS
B110W/KS

ITALIANO

CE



ULTRAFLEX



SOCIO



ULTRAFLEX

Gentile Cliente,

La ringraziamo per aver scelto un prodotto **ULTRAFLEX**.

ULTRAFLEX da anni un punto di riferimento nei sistemi di guida nel settore della nautica da diporto e professionale.

Da sempre la produzione **ULTRAFLEX** sinonimo di grande affidabilità e sicurezza.

Tutti i prodotti **ULTRAFLEX** sono progettati e prodotti per garantire sempre le prestazioni migliori, relativamente allo scopo per cui sono concepiti.

Per tutelare la Vostra sicurezza e per mantenere sempre un alto livello qualitativo **ULTRAFLEX** garantisce i propri prodotti solo se utilizzati con i ricambi originali.

I Sistemi di Gestione Qualità **ULTRAFLEX** ed **UFLEX** sono certificati dal DNV-GL Det Norske Veritas - Germanischer Lloyd, in conformità alla Norma UNI EN ISO 9001:2015.

Il sistema Qualità coinvolge tutte le risorse ed i processi aziendali a partire dalla progettazione, per:

- garantire al cliente la qualità del prodotto;
- impostare le azioni per mantenere e migliorare nel tempo gli standard di qualità ;
- perseguire un continuo miglioramento dell'efficacia e dell'efficienza dei processi per poter essere sempre in sintonia con le esigenze del mercato ed accrescere la soddisfazione dei Clienti.

Il sistema di Gestione Ambientale **ULTRAFLEX** certificato dal DNV-GL Det Norske Veritas - Germanischer Lloyd in conformità alla Norma UNI EN ISO 14001:2015.

I prodotti destinati alla nautica da diporto vengono costantemente controllati per verificare la rispondenza ai requisiti imposti dalla direttiva 2013/53/UE.



"**ULTRAFLEX**, con più di 85 anni di esperienza nel settore nautico oggi leader globale nella produzione di sistemi di guida meccanici, idraulici ed elettronici, scatole di comando e volanti per imbarcazioni a motore da diporto, da pesca o da lavoro di ogni dimensione e tipo di motorizzazione.

L'affidabilità dei nostri prodotti ed il servizio ante e post vendita, la qualità dell'organizzazione aziendale e delle risorse umane insieme agli investimenti continui in ricerca e sviluppo sono fattori determinanti per spiegare il successo crescente dei nostri prodotti ovunque nel mondo".

ULTRAFLEX S.p.A.

16015 Casella (Genova) Italia - Via Crose, 2

INDICE GENERALE

USO DEL MANUALE E SIMBOLOGIA IMPIEGATA	26
LETTERA INFORMATIVA	27
GARANZIA	27

SEZIONE 1 - DESCRIZIONE DEL PRODOTTO

1.1 DESCRIZIONE DEL PRODOTTO E RACCOMANDAZIONI SULL'UTILIZZO	28
1.2 DIMENSIONI	29

SEZIONE 2 - TRASPORTO

2.1 AVVERTENZE GENERALI	30
2.2 CONTENUTO IMBALLO	30

SEZIONE 3 - INSTALLAZIONE

3.1 UTENSILI NECESSARI	32
3.2 INSTALLAZIONE DELLA SCATOLA DI COMANDO	32
3.2.1 VERSIONE LEVA SENZA KILL SWITCH	33
3.2.2 VERSIONE LEVA CON KILL SWITCH	34
3.3 COLLEGAMENTO ELETTRICO KILL SWITCH	35
3.4 INSTALLAZIONE DEL NEUTRAL SAFETY SWITCH (OPZIONALE)	36
3.5 INSTALLAZIONE DEL NEUTRAL SAFETY SWITCH + TILT (OPZIONALE)	37
3.6 MONTAGGIO DEL CAVO INVERTITORE	38
3.6.1 COLLEGAMENTO DEL CAVO INVERTITORE AL TELAIO	38
3.6.2 COLLEGAMENTO DEL CAVO INVERTITORE AL BILANCIERE	39
3.7 MONTAGGIO DEL CAVO ACCELERATORE	40
3.7.1 COLLEGAMENTO DEL CAVO ACCELERATORE AL BILANCIERE	40
3.8 MONTAGGIO GRUPPO LEVA	41
3.9 REGOLAZIONE DELLA FRIZIONE	41
3.10 INSTALLAZIONE CAVI TRIM	41

SEZIONE 4 - USO DELLA LEVA

4.1 USO DELLA LEVA	42
4.2 ACCELERAZIONE IN FOLLE	42
4.3 FUNZIONAMENTO DEL TRIM	42

SEZIONE 5 - AVVERTENZE DI SICUREZZA

5.1 NORME DI SICUREZZA DURANTE L'INSTALLAZIONE E L'USO	43
5.2 ABBIGLIAMENTO	43

SEZIONE 6 - MANUTENZIONE

6.1 MANUTENZIONE ORDINARIA	43
6.2 MANUTENZIONE STRAORDINARIA	44

SEZIONE 7 - SMANTELLAMENTO

7.1 SMANTELLAMENTO	44
--------------------------	----

USO DEL MANUALE E SIMBOLOGIA IMPIEGATA

IL MANUALE DI INSTALLAZIONE E MANUTENZIONE il documento che accompagna il prodotto dal momento della sua vendita fino alla sua sostituzione e smaltimento. Risulta cio essere parte integrante dello stesso. E' richiesta la lettura del manuale prima che venga intrapresa QUALSIASI ATTIVITA' che coinvolga il prodotto compresa la movimentazione e lo scarico dello stesso dal mezzo di trasporto.

Al fine di tutelare la sicurezza dell'utilizzatore e per garantire il corretto funzionamento del prodotto nel presente manuale stata adottata la simbologia di seguito descritta.

PERICOLO



Danni immediati che CAUSANO ferite gravi alla persona o che portano alla morte.

AVVERTENZA



Indica che esiste un pericolo che pu causare lesione o morte se non sono adottate le precauzioni appropriate.

ATTENZIONE



Indica un richiamo all'applicazione di pratiche di sicurezza oppure richiama l'attenzione su pratiche non sicure che potrebbero causare lesione personale o danno all'imbarcazione o ai componenti o all'ambiente.

NOTA



Informazione ritenuta importante per una installazione adeguata e per la manutenzione, che non causa di danni.



Le operazioni per la cui esecuzione si richiede, onde evitare possibili rischi, personale qualificato o specializzato sono evidenziate con il simbolo indicato a lato. Si raccomanda di formare il personale destinato all'installazione del prodotto e di verificare che quanto previsto sia compreso ed attuato.

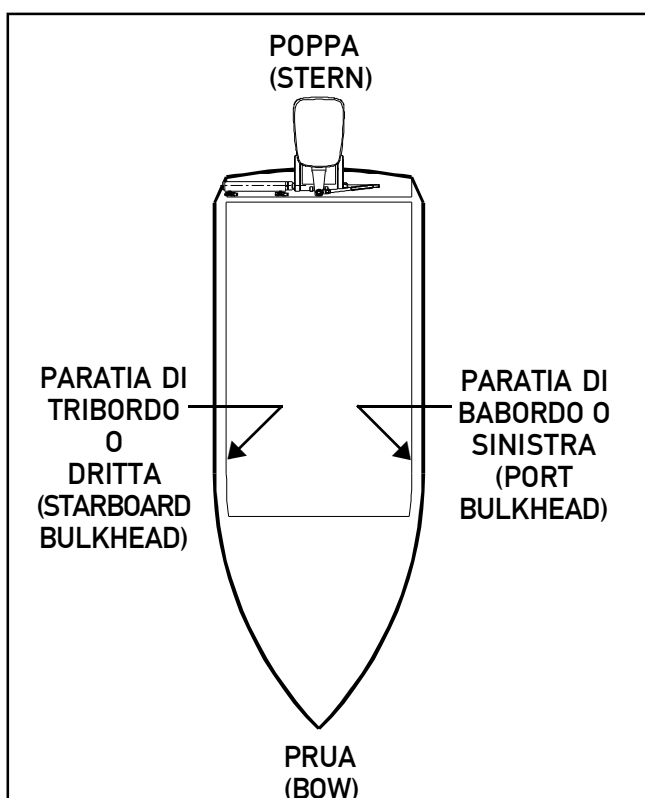

LETTERA INFORMATIVA

Il presente manuale di installazione e manutenzione costituisce parte integrante del prodotto e deve essere facilmente reperibile dal personale addetto all'uso e alla manutenzione dello stesso.

L'utilizzatore tenuto a conoscere il contenuto del presente manuale.

ULTRAFLEX declina ogni responsabilità per eventuali inesattezze dovute ad errori di stampa, contenute nel manuale.

Ferme restando le caratteristiche essenziali del prodotto descritto, **ULTRAFLEX** si riserva il diritto di apportare eventuali modifiche di descrizioni, dettagli e illustrazioni, che riterrà opportuno per il miglioramento dello stesso, o per esigenze di carattere costruttivo o commerciale, in qualunque momento e senza impegnarsi ad aggiornare tempestivamente questa pubblicazione.

TUTTI I DIRITTI SONO RISERVATI. I diritti di pubblicazione, i marchi, le sigle e le fotografie dei prodotti **ULTRAFLEX** presenti in questo manuale sono di proprietà di **ULTRAFLEX** che ne vieta qualsiasi riproduzione anche parziale. Ogni cura è stata posta nella raccolta e nella verifica della documentazione per rendere questo manuale il più completo e comprensibile possibile. Nulla di quanto contenuto nella presente pubblicazione può essere interpretato come garanzia o condizione espressa o implicita - inclusa, non in via limitativa, la garanzia di idoneità per un particolare scopo. Nulla di quanto contenuto nella presente pubblicazione può inoltre essere interpretato come modifica o asserzione dei termini di qualsivoglia contratto di acquisto.

⚠ AVVERTENZA

Al fine di assicurare il corretto funzionamento del prodotto e dei suoi componenti, lo stesso deve essere installato da personale esperto. In caso di rotture di parti componenti o malfunzionamento, rivolgersi al personale specializzato o contattare il nostro Servizio Assistenza Tecnica.

SERVIZIO ASSISTENZA TECNICA

UFLEX S.r.l.

Via Milite Ignoto,8A
16012 Busalla (GE)-Italia
Tel: +39.010.962.01
Email: service@ultraflexgroup.it
www.ultraflexgroup.it

Nord - Sud - Centro America:

UFLEX USA

6442 Parkland Drive
Sarasota, FL 34243
Tel: +1.941.351.2628
Email: sales@uflexusa.com
www.uflexusa.com

GARANZIA

ULTRAFLEX garantisce che i suoi prodotti sono costruiti a regola d'arte e che sono privi di difetti di fabbricazione e di materiali.

Questa garanzia è valida per un periodo di due anni decorrenti dalla data di fabbricazione dei prodotti ad eccezione dei casi in cui questi siano installati ed usati su barche da lavoro o comunque su barche ad utilizzo commerciale, nel qual caso la garanzia è limitata ad 1 anno dalla data di fabbricazione.

Questa garanzia è limitata alla sostituzione o riparazione gratuita del pezzo che, entro il termine suddetto, ci sarà restituito in porto franco e che rileveremo essere effettivamente difettoso nei materiali o/e nella fabbricazione.

È escluso dalla garanzia ogni e qualsiasi altro danno diretto o indiretto. In particolare, è escluso dalla garanzia e da ogni nostra responsabilità (tranne quella di sostituire o riparare, nei termini e condizioni suddette, i pezzi difettosi) il malfunzionamento dei nostri prodotti qualora il loro mancato o difettoso funzionamento sia attribuibile ad una errata installazione o ad uso negligente o improprio.

Questa garanzia non copre i prodotti installati su barche da corsa o utilizzate in contesti competitivi. Le descrizioni e le illustrazioni di questo manuale s'intendono fornite a titolo indicativo.

Per informazioni dettagliate si prega di contattare il nostro Servizio Assistenza.

I componenti dei sistemi di guida **ULTRAFLEX** sono marcati **CE** come richiesto dalla direttiva 2013/53/UE.

Vi ricordiamo che sulle imbarcazioni marcate **CE** è obbligatorio installare sistemi di guida i cui componenti siano marcati **CE**. Vi informiamo che la garanzia **ULTRAFLEX** decade automaticamente qualora alcuni componenti **ULTRAFLEX** siano installati in un sistema di guida insieme a prodotti di altre marche.



1 DESCRIZIONE DEL PRODOTTO

1.1 Descrizione del prodotto e raccomandazioni sull'utilizzo

Il comando, di tipo monoleva, va montato su un lato della console principale dell'imbarcazione. La leva dispone di frizione regolabile, di dispositivo a pulsante per azionare il gas con invertitore in folle e di pulsante per la regolazione del trim.

Il comando monoleva **B110** prevede la fornitura di un kit standard per l'utilizzo della leva con i seguenti cavi **ULTRAFLEX**:

- **C2 - C8 - MACHZero** (cavi classe 33C);

Se il Cliente dovesse montare la leva su motori che prevedono l'uso di cavi di altro tipo rispetto a quelli sopra indicati, dovrà essere utilizzato un kit specifico (opzionale) per la loro installazione come specificato di seguito:

KIT K74: cavi C5 e MACH5 (Mercury® GEN I)

KIT K75: cavi C36 e MACH36 (Mercury® GEN II)

KIT K76: cavo C14 (OMC®, EVINRUDE®)

In tal caso, il kit standard fornito in dotazione dovrà essere messo da parte e non utilizzato.

⚠ ATTENZIONE

Nel caso di utilizzo di un kit opzionale, seguire le istruzioni fornite con lo stesso.

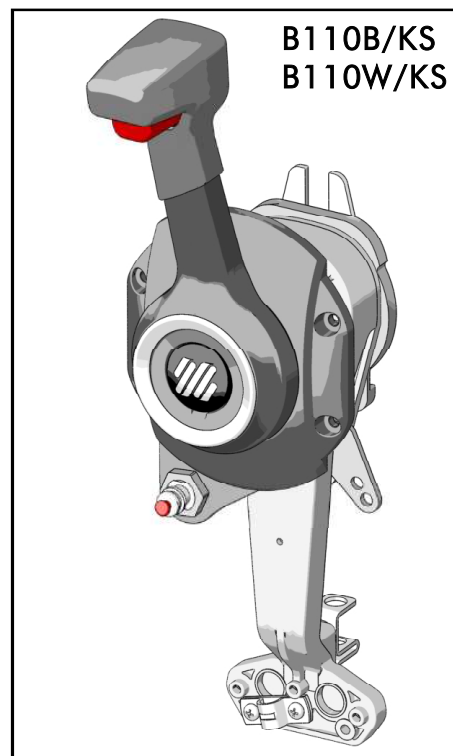
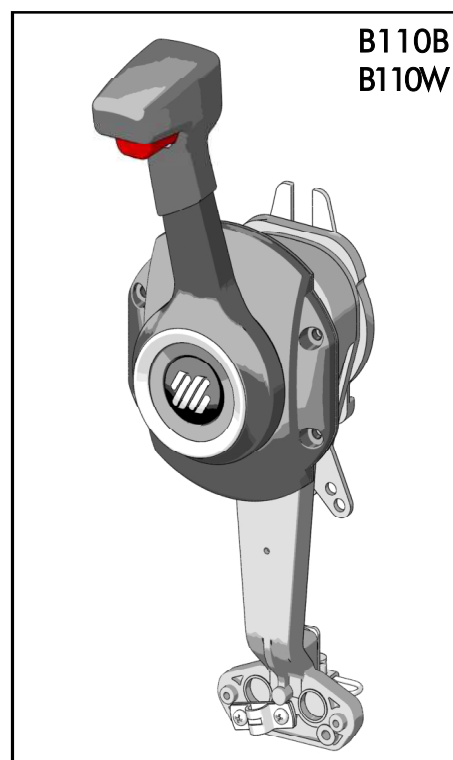

1.2 Dimensioni

Le figure seguenti indicano le dimensioni dei quattro modelli di comando monoleva B110.

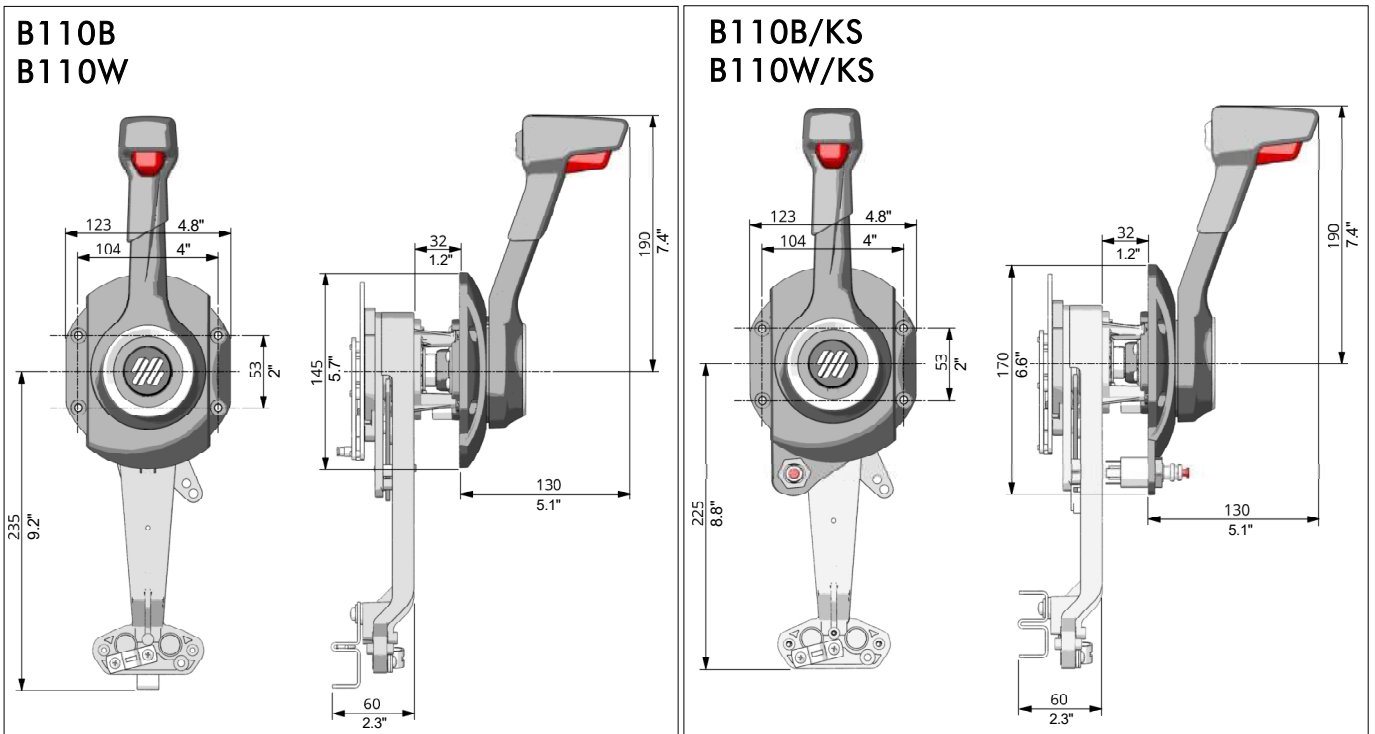

ITALIANO

DIMENSIONI DI INGOMBRO MINIME PER LA ROTAZIONE DELLA LEVA

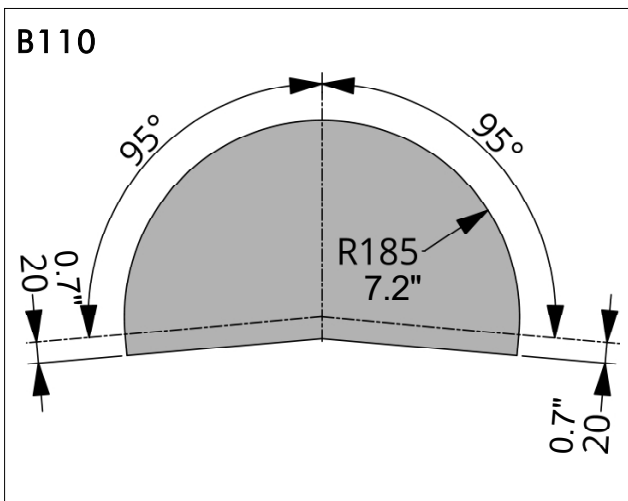

NOTA

Assicurarsi che la leva possa ruotare liberamente e la sua corsa non sia impedita da ostacoli.



2 TRASPORTO

2.1 Avvertenze generali

Il peso del prodotto con il suo imballo di circa 2.5Kg (5,5 pounds) e quindi la sua movimentazione pu essere effettuata manualmente.

⚠️ AVVERTENZA

Il personale addetto alla manipolazione del carico deve operare con guanti protettivi e scarpe antinfortunistiche.

2.2 Contenuto imballo

Prima dell'installazione dell'apparecchiatura verificare che non abbia subito danneggiamenti dovuti al trasporto o alle condizioni di conservazione. Verificare inoltre che tutti i componenti forniti di serie siano contenuti nell'imballo (vedi elenco). In caso di danneggiamento, notificare il reclamo allo spedizioniere ed avvisare il vostro fornitore.

Contenuto degli imballi della scatola di comando:

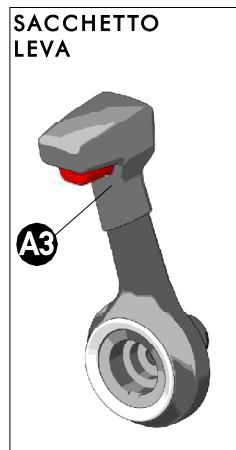
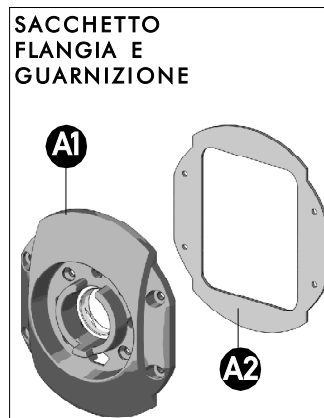
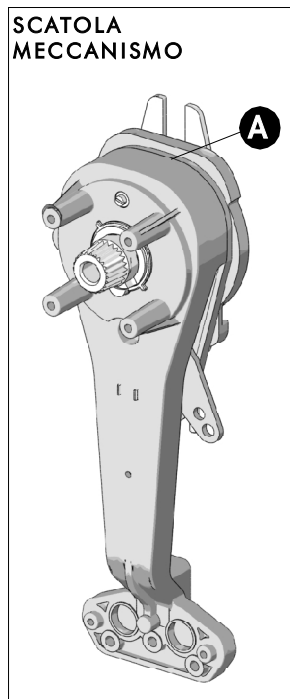

RIF	COMPONENTE
A	scatola di comando
A1	flangia
A2	guarnizione
A3	leva
A4	pulsante

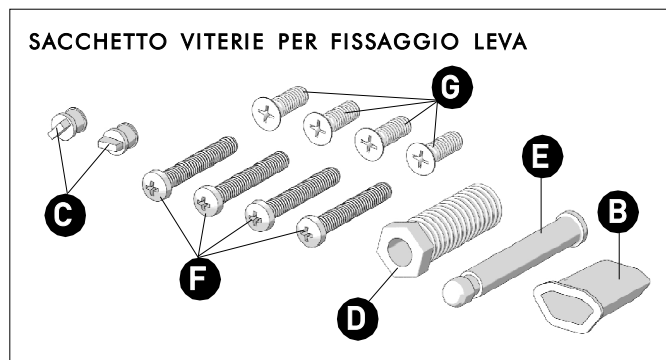

RIF	COMPONENTE
B	gommino passacavi
C	tappi
D	vite fissaggio leva
E	perno
F	viti fissaggio flangia
G	viti fissaggio meccanismo



SACCHETTO MINUTERIE PER CAVI C2 - C8 - MACHZero

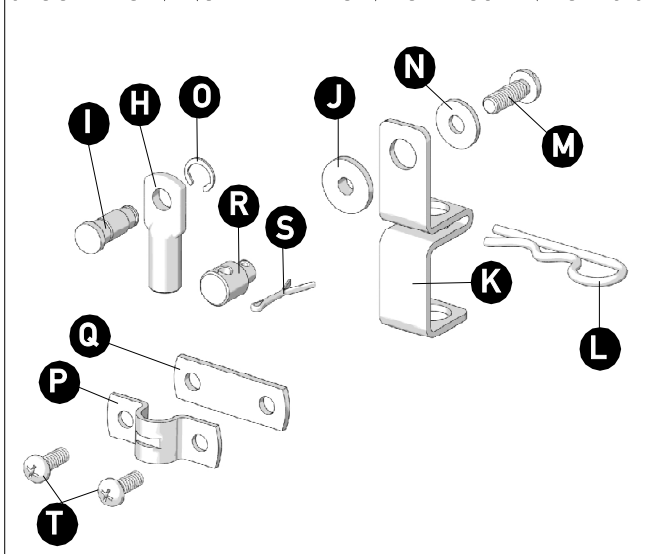

RIF	COMPONENTE
H	terminale cavo acceleratore
I	perno fermacavo
J	boccola fermaguaina
K	fermaguaina
L	copiglia elastica
M	vite
N	rondella
O	seeger
P	cavallotto
Q	piastrina
R	terminale cavo
S	copiglia
T	viti

Nel caso in cui la leva fosse dotata di kill switch (modelli B110B/KS e B110W/KS), verrà fornito un ulteriore kit (in aggiunta a quelli descritti alla pagina precedente) composto dal cordino con clip di fissaggio, dal dado e dallo switch stesso.

Tali componenti verranno forniti in un unico sacchetto.

SACCHETTO COMPONENTI PER LEVA CON KILL SWITCH

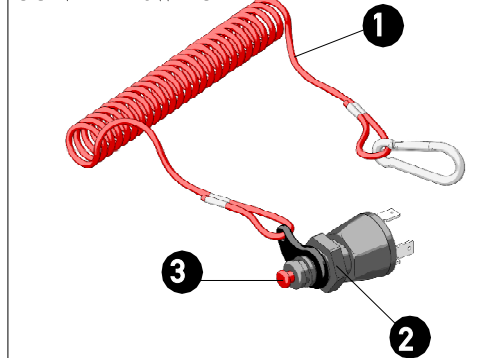

RIF	COMPONENTE
1	cordino con clip di fissaggio
2	dado
3	kill switch

NOTA

Per un'installazione corretta del kill switch, fare riferimento al paragrafo 3.2.2.

⚠ ATTENZIONE

Gli imballi devono essere smaltiti secondo le direttive vigenti.



3 INSTALLAZIONE

3.1 Utensili necessari



Cacciavite a stella (Ø6)



Cacciavite a taglio (Ø2)



Pinza



Chiave a tubo 14 mm



Trapano

3.2 Installazione della scatola di comando



NOTA

In funzione dei cavi di comando, è possibile montare il meccanismo in posizione orizzontale o verticale come mostrato nelle figure a fianco, ruotando il meccanismo interno in modo tale da far corrispondere il foro di ispezione della flangia con la vite di regolazione della frizione del meccanismo (vedi cap. 3.9).

Tale considerazione è valida anche per i modelli di leva con kill switch.

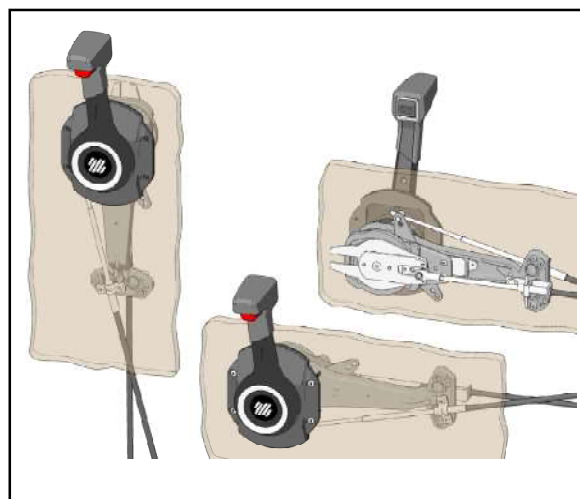

⚠ ATTENZIONE

Utilizzare i tappi "C" forniti nel sacchetto viterie per chiudere due dei tre fori di ispezione non utilizzati nella flangia. Tale considerazione è valida anche per i modelli di leva con kill switch.

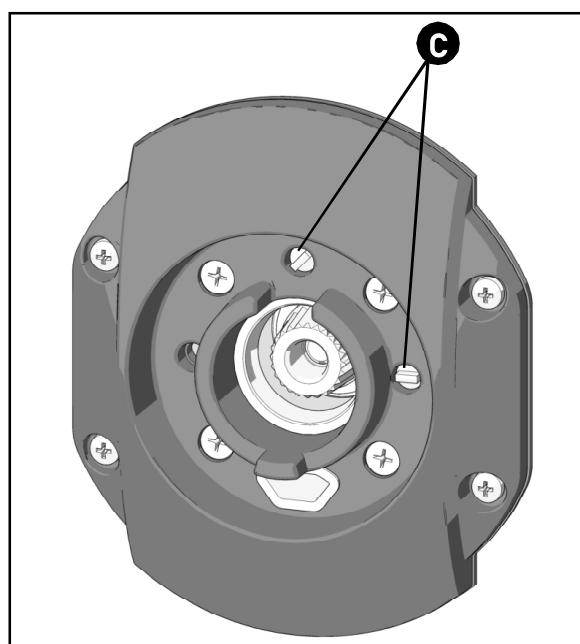

3.2.1 Versione leva senza kill switch

⚠ ATTENZIONE

Evitare che i cavi siano sottoposti a curvature troppo strette (raggio minimo: 200 mm - 8"). Si raccomanda l'uso di cavi **ULTRAFLEX**.

1 Riferirsi alla quote di ingombro indicate al paragrafo 1.2 per verificare che la scatola possa essere effettivamente installata nella posizione prescelta.

2 Dopo aver stabilito la collocazione appropriata, eseguire la foratura necessaria all'inserimento della scatola di comando con l'ausilio dell'apposita dima (allegata). necessario che lo spessore della superficie di installazione della leva non sia superiore a 20mm (0.7").

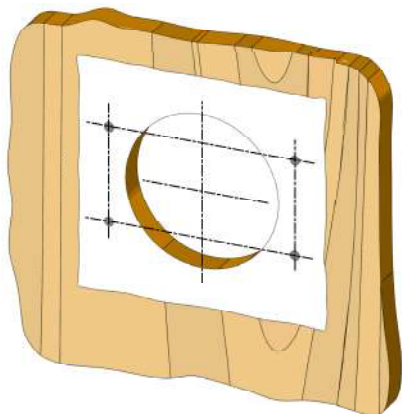

3 Fissare la flangia (A1) e la relativa guarnizione (A2) per mezzo delle viti (F).

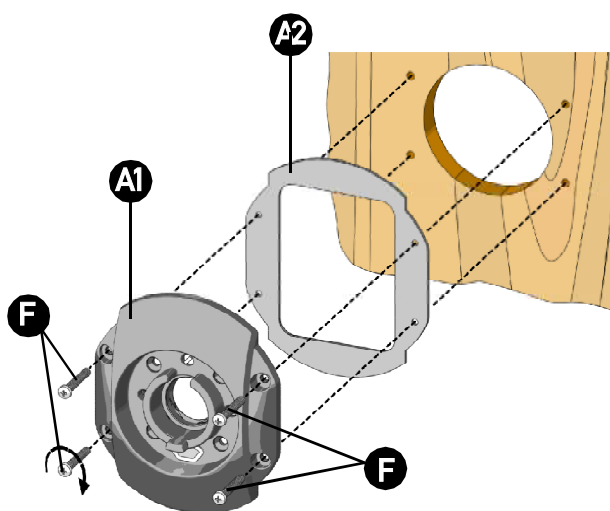

4 Fissare il meccanismo della scatola di comando (A) alla flangia (A1) per mezzo delle viti (G).

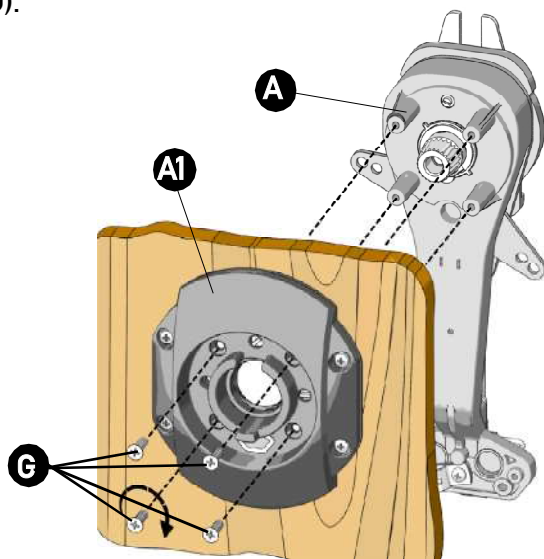

NOTA

I cavi acceleratore ed invertitore vanno collegati successivamente al telaio ed ai bilancieri secondo le istruzioni al capitolo 3.6 e 3.7.



3.2.2 Versione leva con kill switch

⚠ ATTENZIONE

Evitare che i cavi siano sottoposti a curvature troppo strette (raggio minimo: 200 mm - 8"). Si raccomanda l'uso di cavi **ULTRAFLEX**.

1 Riferirsi alla quote di ingombro indicate al paragrafo 1.2 per verificare che la scatola possa essere effettivamente installata nella posizione prescelta.

2 Dopo aver stabilito la collocazione appropriata, eseguire la foratura necessaria all'inserimento della scatola di comando con l'ausilio dell'apposita dima (allegata). necessario che lo spessore della superficie di installazione della leva non sia superiore a 20mm (0.7").

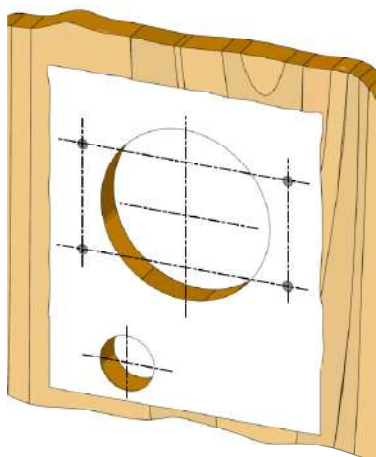

3 Lo switch (1) deve essere avvitato al pacchetto costituito dalla flangia (A1) e dalla guarnizione (A2), mediante il dado 2.

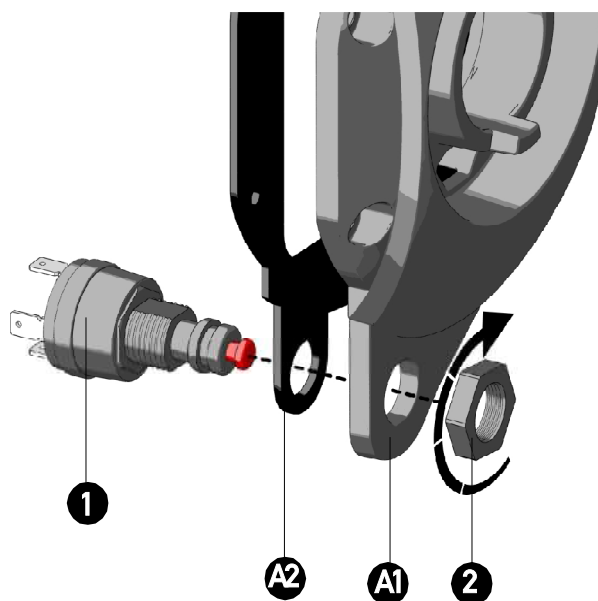

4 Fissare la flangia (A1) e la relativa guarnizione (A2) per mezzo delle viti (F).

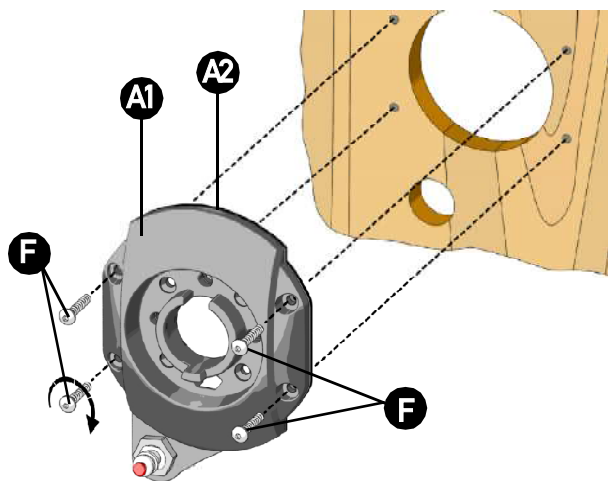

5 Fissare il meccanismo della scatola di comando (A) alla flangia (A1) per mezzo delle viti (G).

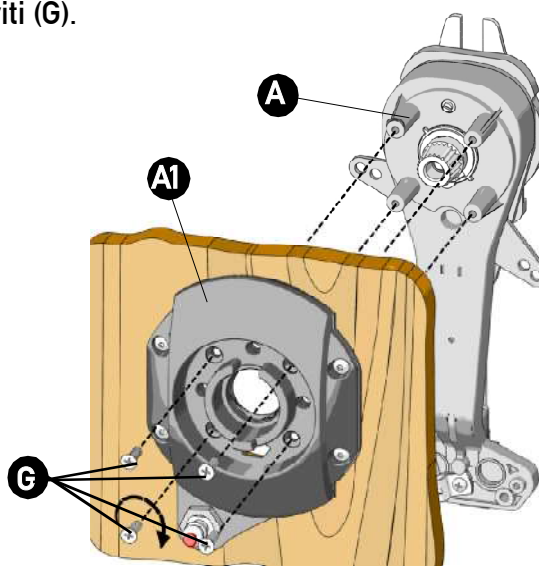

3.3 Collegamento elettrico kill switch



⚠ AVVERTENZA

Per un corretto collegamento dello switch, necessario fare riferimento allo schema generico di cablaggio riportato di seguito. L'utente deve in ogni caso effettuare i collegamenti considerando il tipo di impianto elettrico presente sulla propria imbarcazione.

⚠ AVVERTENZA

Un'installazione errata dello switch pu causare lesioni fisiche gravi o addirittura mortali.

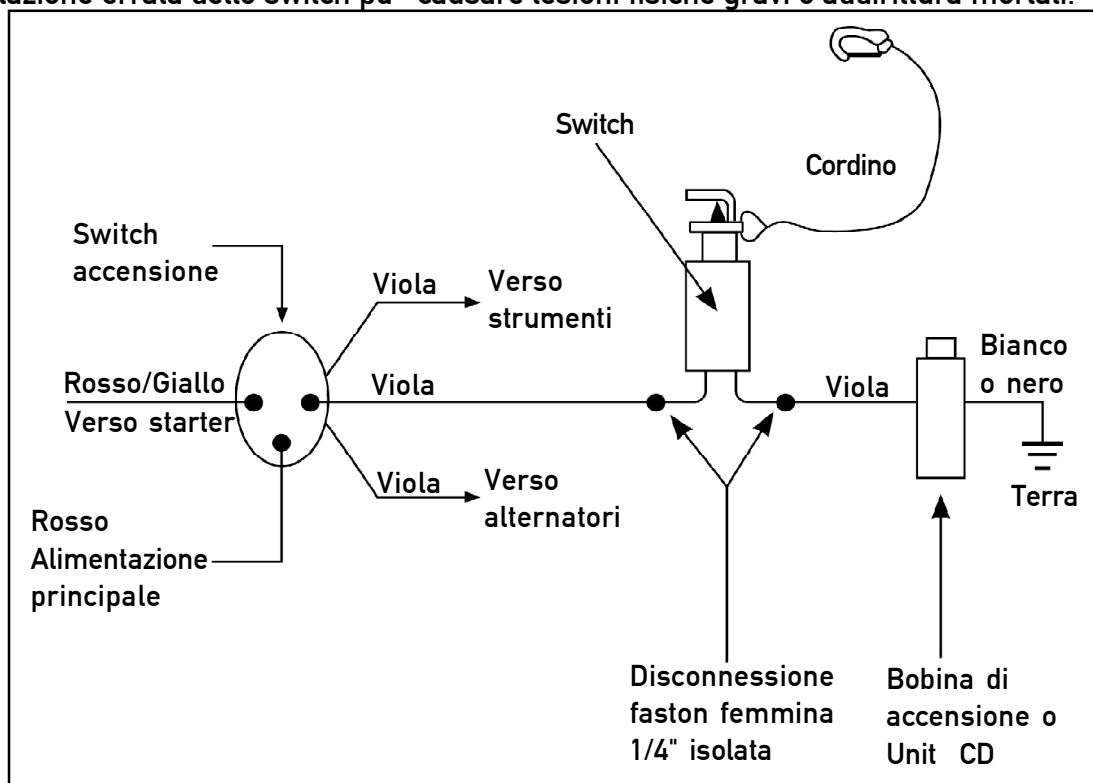

Lo switch è dotato di una clip con un cordino che mantiene il pistoncino dello switch stesso in una posizione tale da garantire il funzionamento del motore. Il cordino, mediante la clip, è connesso all'operatore in sicurezza. Se l'operatore si allontana dai comandi, la clip si scollega rilasciando il pistoncino e arrestando il motore.

Per un corretto funzionamento del kill switch, eseguire le operazioni seguenti:

- 1) prima che venga acceso il motore, verificare che la clip di fissaggio del cordino sia posizionata correttamente sullo switch e che possa ruotare liberamente.
- 2) verificare le condizioni del cordino: se questo fosse tagliato, usurato o sfilacciato, sostituirlo.
- 3) avviare il motore
- 4) testare lo switch scollegando la clip di fissaggio del cordino dallo stesso: il motore deve arrestarsi.

⚠ AVVERTENZA

Se il motore non dovesse arrestarsi, verificare l'intero cablaggio.

Se il motore non si avvia, non si arresta o riprende a funzionare con la clip del cordino scollegata, contattate il vostro rivenditore di materiale nautico di zona per richiedere assistenza.

⚠ AVVERTENZA

È vietato modificare la lunghezza del cordino o utilizzare il cordino fornito da un altro produttore con questo switch; ci si può comprometterne il corretto funzionamento.

L'uso scorretto, modifiche non autorizzate o un'installazione errata di questo dispositivo di sicurezza pu causare lesioni fisiche gravi o addirittura mortali.



3.4 Installazione del neutral safety switch (opzionale)



Questo dispositivo (opzionale) consente l'avvio del motore solo con la leva in posizione di "neutral", evitando movimenti indesiderati dell'imbarcazione.

Per il montaggio, procedere come segue:

Fissare l'interruttore di sicurezza X41 con vite (1), rondella (2) e dado (3) (inclusi nel kit X41), come in figura.

NOTA

La testa della vite deve appoggiare sulla superficie dell'interruttore.

Per un corretto funzionamento del neutral safety switch X41, eseguire le operazioni seguenti:

- 1) prima che venga acceso il motore, verificare che lo switch sia installato correttamente.
- 2) muovere la leva avanti ed indietro (passando dalla posizione NEUTRAL) e verificare che lo switch commuti.
- 3) cablare lo switch prestando particolare attenzione agli schemi elettrici e ai collegamenti
- 4) accendere il motore e verificare che il sistema lavori correttamente.

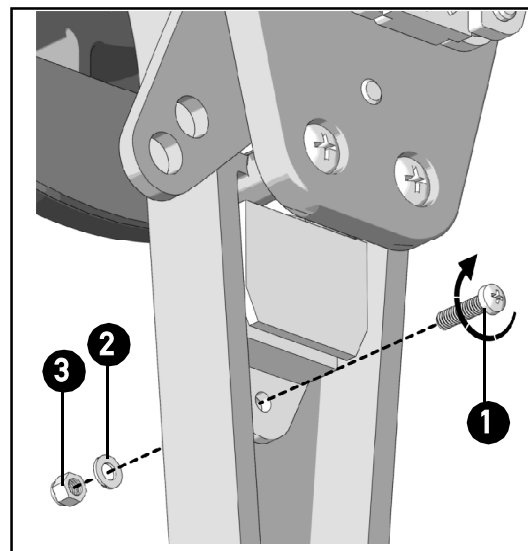
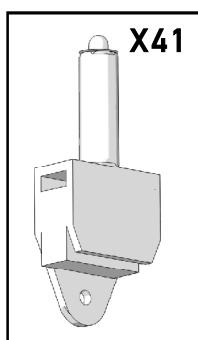

⚠ ATTENZIONE

Quando la leva in posizione di NEUTRAL, il circuito deve risultare chiuso; quando invece in posizione differente, deve risultare aperto.

⚠ AVVERTENZA

Se il motore dovesse accendersi anche quando la leva non in posizione di NEUTRAL, verificare l'intero cablaggio. L'uso scorretto, modifiche non autorizzate o un'installazione errata di questo neutral safety switch pu causare lesioni fisiche gravi o addirittura mortali.



3.5 Installazione del neutral safety switch + tilt (opzionale)



Questo dispositivo (opzionale) consente l'avvio del motore solo con la leva in posizione di "neutral", evitando movimenti indesiderati dell'imbarcazione e allo stesso tempo, utilizzando lo switch sulla leva, permette di comandare il tilt del motore.

Per il montaggio, procedere come segue:

Fissare l'interruttore di sicurezza X48 con vite (1), rondella (2) e dado (3) (inclusi nel kit X48), come in figura.

NOTA

La testa della vite deve appoggiare sulla superficie dell'interruttore.

Per un corretto funzionamento del neutral safety switch X48, eseguire le operazioni seguenti:

- 1) prima che venga acceso il motore, verificare che lo switch sia installato correttamente.
- 2) muovere la leva avanti ed indietro (passando dalla posizione NEUTRAL) e verificare che lo switch commuti.
- 3) cablare lo switch prestando particolare attenzione agli schemi elettrici e ai collegamenti
- 4) accendere il motore e verificare che il sistema lavori correttamente.

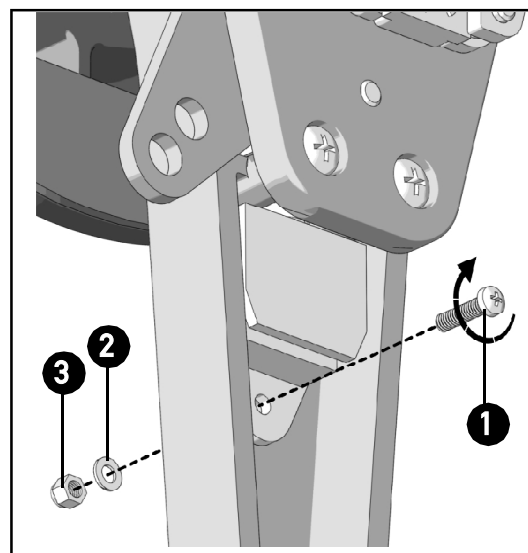
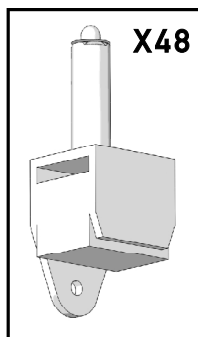

⚠ ATTENZIONE

Quando la leva in posizione di NEUTRAL, entrambi i circuiti devono risultare chiusi; quando invece in posizione differente, devono risultare entrambi aperti.

⚠ AVVERTENZA

Se il motore dovesse accendersi anche quando la leva non in posizione di NEUTRAL, verificare l'intero cablaggio. L'uso scorretto, modifiche non autorizzate o un'installazione errata di questo neutral safety switch pu causare lesioni fisiche gravi o addirittura mortali.



3.6 Montaggio del cavo invertitore



⚠ ATTENZIONE

Prima di iniziare l'installazione assicurarsi che il bilanciere dell'invertitore sia in posizione di neutral (orizzontale) e l'acceleratore in posizione di minimo (posizione mostrata in figura).

Identificare su quale lato del telaio sarà necessario installare il cavo invertitore a seconda che sia necessario un movimento a tirare o a spingere il cavo.

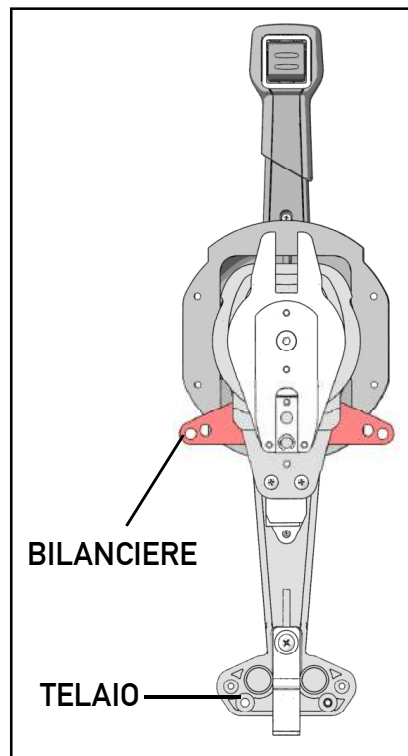

3.6.1 Collegamento del cavo invertitore al telaio

- 1 Fissare il terminale guaina del cavo invertitore al telaio per mezzo dell'apposita piastrina (Q) e cavallotto (P) per mezzo delle viti (T). quindi serrare le viti.

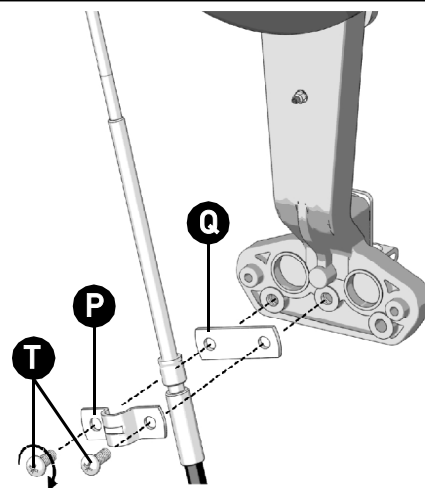

3.6.2 Collegamento del cavo invertitore al bilanciere

1 Avvitare il terminale cavo (R) sulla filettatura in testa al cavo invertitore.

Chiudere o estendere il cavo in modo da inserire il terminale sul foro del bilanciere. Verificare che il cavo faccia tutta la corsa necessaria. Se la corsa è corretta serrare il controdado (1) e inserire l'apposita copiglia (S) nel terminale cavo per impedirle lo sfilamento dal bilanciere. Se la corsa non fosse quella desiderata, avvitare o svitare il terminale sulla filettatura in testa al cavo per ottenere una regolazione più fine, quindi serrare il controdado (1) e inserire l'apposita copiglia (S) nel terminale cavo.

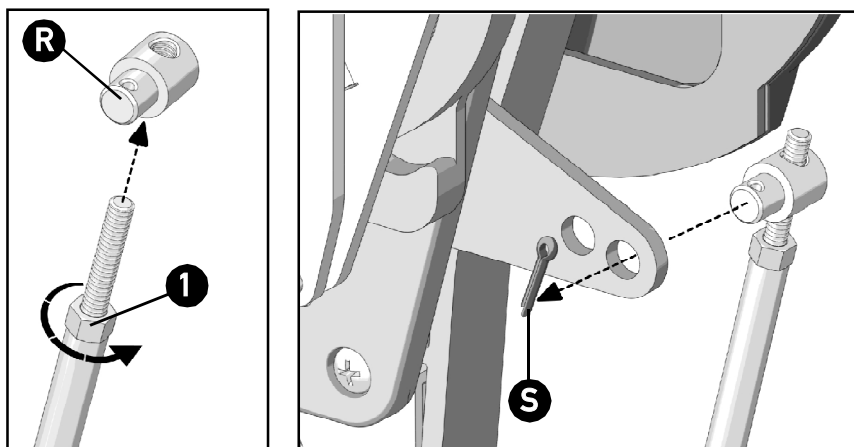

⚠ ATTENZIONE

- Il corretto funzionamento del comando dipende dall'esatta regolazione della corsa dell'invertitore.

⚠ ATTENZIONE

In nessun caso la corsa sviluppata dal comando monoleva (67 mm (2.64") sul foro interno; 78 mm (3.0") sul foro esterno del bilanciere) deve risultare superiore alla corsa misurata sulla leva del motore.

Ci potrebbe danneggiare sia il cavo che il comando.

- Le guaine dei cavi, uscenti dalla parte inferiore del comando, possono essere fasciate in gruppo o fissate ad una distanza minima di 500 mm (19.7") dal comando stesso.





3.7 Montaggio del cavo acceleratore

Di seguito, vengono fornite le istruzioni per il collegamento del cavo acceleratore.

1 Ruotare la leva di almeno 45° in modo tale da portare la slitta nella barte bassa del bilanciere in una posizione che permetta l'inserimento del perno (vedi figura). Inserire il perno (I) nel foro esterno della slitta dalla parte inferiore del bilanciere verso quella superiore (vedi figura) e bloccarlo con il seeger (O).

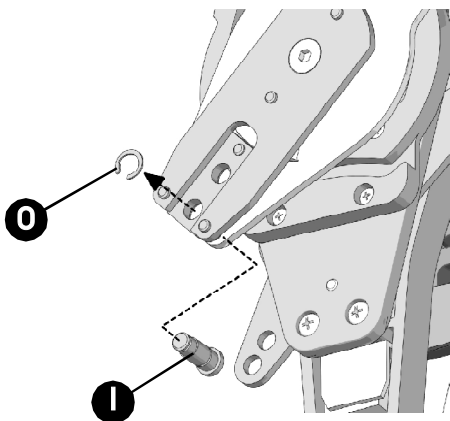

2 Fissare il fermaguaina (K) al meccanismo tramite la boccia fermaguaina (J), la rondella (N) e la vite (M). Inserire quindi il cavo nel fermaguaina (K), assicurandosi che questo sia girato verso l'esterno, come in figura. Fermarlo inserendo la copiglia elastica (L) nella sede al centro del fermaguaina.

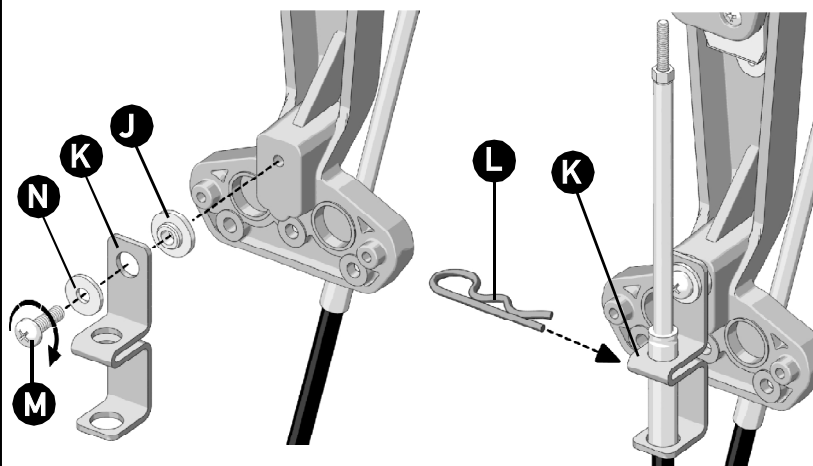

3.7.1 Collegamento del cavo acceleratore al bilanciere

1 Avvitare il terminale cavo (H) sulla filettatura in testa al cavo acceleratore.

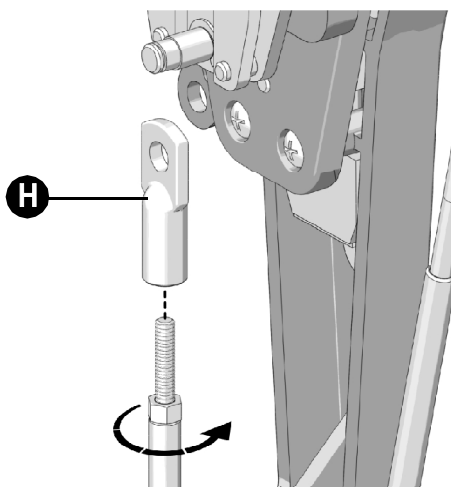

2 Inserire il puntale sul perno (I) e fissarlo con il seeger (O).

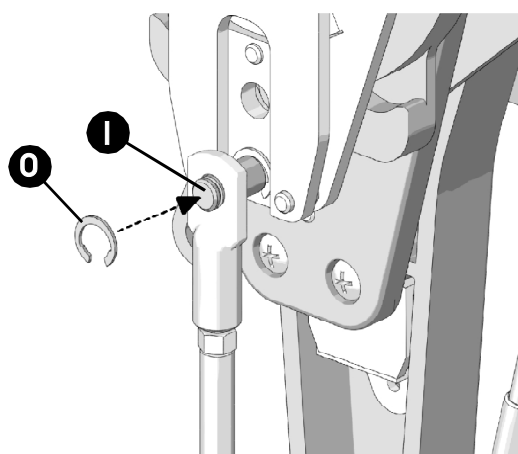

⚠ ATTENZIONE

- Il corretto funzionamento del comando dipende dall'esatta regolazione della corsa dell'acceleratore.



3.8 Montaggio gruppo leva



1 Posizionare il gommino passacavi (B) nell'asola presente nella parte inferiore della flangia e inserire il cavo del trim in uscita dalla leva (A3) attraverso di esso. Guidando i cavi verso il meccanismo, inserire la leva in posizione neutral (verticale) nella scatola di comando sull'albero millerighe. Inserire la vite (D) provvista di perno (E) e stringerla utilizzando una chiave da 14mm. Inserire infine il pulsante (A4) nella sua sede sul mozzo della leva, premendo fino ad avvertirne lo scatto. Tale procedura valida anche per i modelli di leva con kill switch.

⚠ ATTENZIONE

Il gommino passacavi deve essere installato in quanto protegge i cavi stessi da eventuali danneggiamenti.

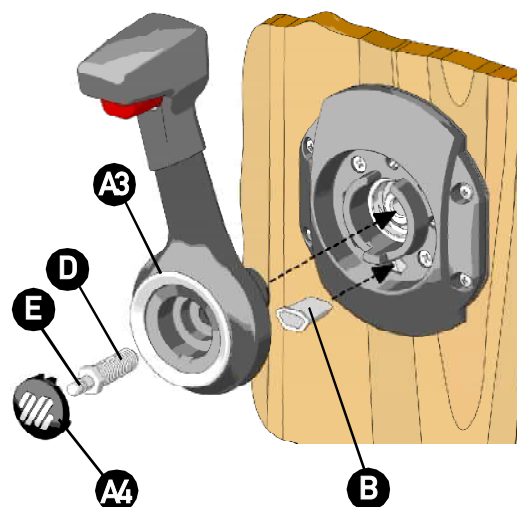

3.9 Regolazione della frizione



1 Accedere alla vite di regolazione della frizione agendo con un cacciavite a taglio. Ruotare la vite in senso orario per aumentare il frizionamento, in senso antiorario per diminuirlo.

NOTA

LA REGOLAZIONE DELLA FRIZIONE DEVE ESSERE ESEGUITA SEMPRE A MOTORE SPENTO. SMONTANDO LA LEVA DALLA SUA FLANGIA.

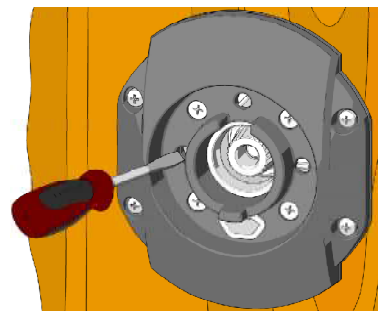

3.10 Installazione cavi trim



I TRIM consentono di modificare la posizione dei motori alzandoli o abbassandoli. Lo schema riportato accanto ha lo scopo di indicare la modalit  di collegamento dei tre fili verde (motore up), rosso (comune) e bianco (motore down).

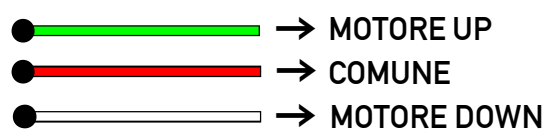

NOTA

Per un corretto funzionamento del TRIM, eseguire le operazioni seguenti:

- 1) prima che venga acceso il motore, verificare che i cavi elettrici del TRIM siano stati fascettati nella maniera corretta vicino al piede del meccanismo (verificando che non risultino troppo tirati, lasciando ricchezza sufficiente).
- 2) cablare il TRIM prestando particolare attenzione agli schemi elettrici e ai collegamenti.
- 3) alimentare l'apparato e verificare che il sistema lavori correttamente.

⚠ AVVERTENZA

vietato modificare in qualsiasi sua parte questo switch: ci pu comprometterne il corretto funzionamento. L'uso scorretto, modifiche non autorizzate o un'installazione errata di questo dispositivo di sicurezza possono causare lesioni fisiche gravi o addirittura mortali.

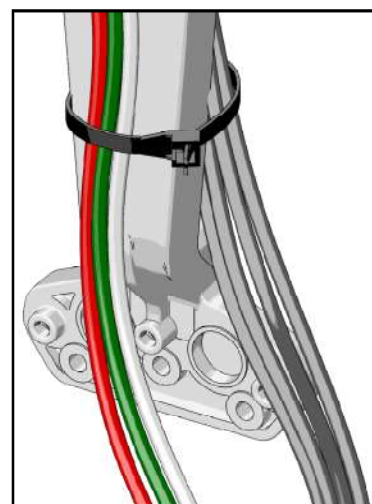

4 USO DELLA LEVA

4.1 Uso della leva

La leva viene mantenuta in posizione neutral (verticale); per sbloccarla, necessario premere il grilletto posizionato sotto l'impugnatura. La corsa della leva divisa in due movimenti: nella prima fase di 30° si aziona l'invertitore, nei successivi 65° si aziona l'acceleratore. Portando la leva in avanti si ottiene l'avanzamento dell'imbarcazione, mentre all'indietro si procede in retromarcia.

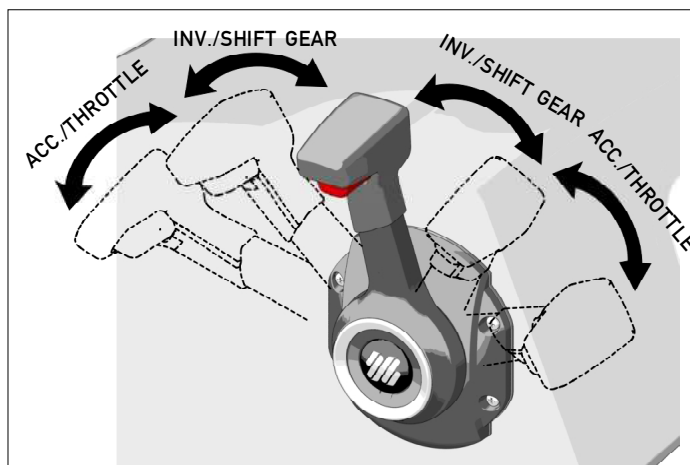

⚠ PERICOLO

Prima di avviare il motore, se il comando sprovvisto di neutral safety switch, accertarsi che la leva sia in posizione di neutral.



4.2 Accelerazione in folle

Premere il pulsante centrale e, mantenendolo schiacciato, ruotare la monoleva in senso orario od antiorario fino ad ottenere il numero di giri voluto.

Riposizionando la leva in folle, la molla di richiamo riporter il pulsante nella posizione iniziale.

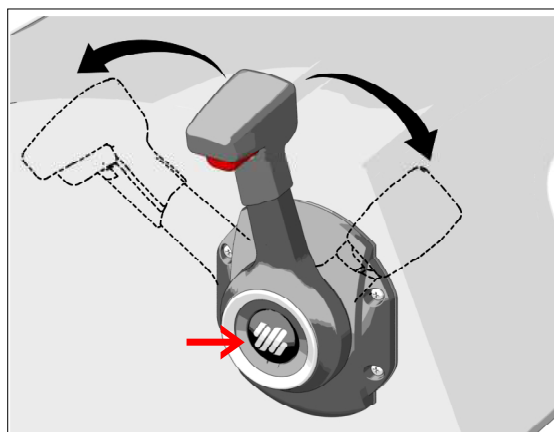

4.3 Funzionamento del trim

Il trim consente di variare l'assetto dell'imbarcazione in movimento agendo sull'inclinazione dei motori.

⚠ AVVERTENZA

Nel caso in cui l'utilizzatore abbia acquistato il neutral safety switch + tilt opzionale (kit X48), necessario consultare le relative istruzioni di installazione e funzionamento riportate al paragrafo 3.5.

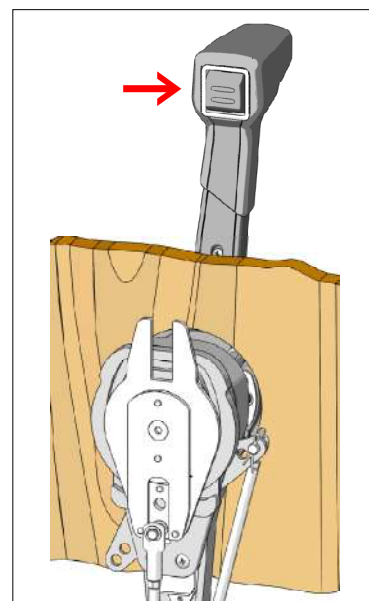

5 AVVERTENZE DI SICUREZZA

Questa sezione ha lo scopo di illustrare le norme di sicurezza da seguire per un uso corretto dell'apparecchiatura. Si raccomanda di leggere con molta attenzione questa sezione. Si raccomanda di leggere i manuali forniti con gli altri componenti del comando monoleva.

5.1 Norme di sicurezza durante l'installazione e l'uso

RISPETTATE TASSATIVAMENTE le precauzioni ed i criteri di sicurezza indicati qui di seguito.

ULTRAFLEX declina ogni responsabilità nel caso in cui l'utilizzatore non li osservi, così come non è responsabile per qualsiasi tipo di negligenza che venga commessa durante l'utilizzo del sistema.

PERICOLO

- **NON INSERIRE LE MANI TRA ORGANI IN MOVIMENTO.**
- Non disattivare o rendere in qualsiasi modo non operativi i dispositivi di sicurezza.
- Non modificare o aggiungere dispositivi all'impianto, senza autorizzazione scritta o previo intervento tecnico **ULTRAFLEX** che comproui nella descrizione dell'intervento la modifica apportata.
- Non utilizzare l'apparecchiatura per uno scopo diverso da quello per cui è stata destinata, specificato nel manuale di installazione e manutenzione.
- Non far eseguire l'installazione a personale non specializzato.

AVVERTENZA

- In fase d'installazione del sistema, avere particolare cura nel mantenere la massima pulizia, per evitare che qualunque corpo estraneo possa penetrare nel sistema stesso. Anche il più piccolo oggetto potrebbe arrecare danni permanenti non immediatamente rilevabili.
- Evitare raggi di curvatura dei cavi <200 mm (8").
- Evitare il contatto dei cavi con bordi o spigoli taglienti.
- Evitare il contatto dei cavi con fonti di calore.

5.2 Abbigliamento

AVVERTENZA

Durante le fasi di installazione, ispezione o manutenzione.

È SEVERAMENTE PROIBITO indossare collane, braccialetti o indumenti che potrebbero impigliarsi in parti in movimento.

6 MANUTENZIONE

6.1 Manutenzione ordinaria

AVVERTENZA

La mancata osservanza dei controlli di manutenzione può causare la perdita di guida con possibili danni materiali e/o lesioni personali.

I requisiti per la manutenzione variano secondo il clima, la frequenza ed il modo d'impiego. Sono necessarie ispezioni almeno annuali effettuate da un esperto meccanico nautico.

Effettuare le seguenti operazioni di manutenzione:

- Periodicamente lavare con acqua dolce i componenti rimuovendo eventuali depositi di sale.
- Ad intervalli mensili regolari controllare ed eventualmente stringere tutti i dadi di fissaggio del sistema.

⚠ PERICOLO

L'allentamento o la separazione dei dadi di fissaggio pu causare, oltre al malfunzionamento del comando monoleva, danni a persone e a cose.

- Periodicamente controllare che non vi sia corrosione sulle parti metalliche dei terminali del cavo e abrasioni sulla guaina.
- Sostituire le parti danneggiate che possono compromettere l'integrità del comando monoleva.

6.2 Manutenzione straordinaria

Assistenza tecnica

Per qualsiasi informazione o per assistenza relativa ad applicazioni particolari, Vi invitiamo a contattare il nostro servizio di assistenza tecnica (Vedi paragrafo "Lettera informativa").

7 SMANTELLAMENTO

7.1 Smantellamento

Qualora si intenda, per qualsiasi motivo, mettere fuori servizio il sistema di comando, è necessario osservare alcune regole fondamentali atte a salvaguardare l'ambiente.

Guaine, condotti flessibili, componenti di materiale plastico o comunque non metallico, dovranno essere smontati e smaltiti separatamente.

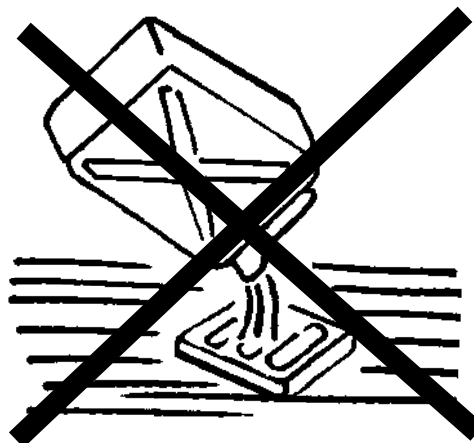

Manuel d'installation et d'entretien

COMMANDE MONO-MANETTE

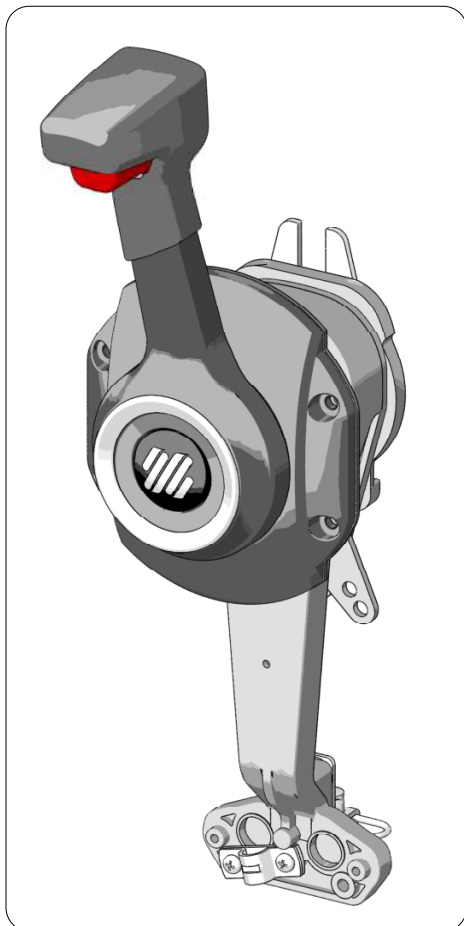

B110B
B110W

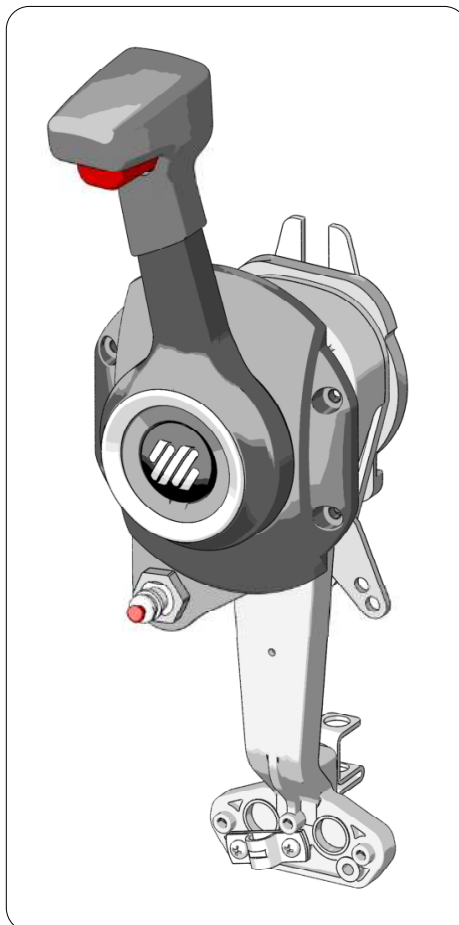

B110B/KS
B110W/KS

CE



ULTRAFLEX



SOCIO

MEMBER
ABYC
Setting Standards for Safer Boating®





Cher Client,

Nous vous remercions pour avoir choisi un produit **ULTRAFLEX**.

La Société **ULTRAFLEX** est depuis plusieurs années un point de repère dans les systèmes de direction et des contrôleurs du moteur dans les domaines de la navigation de plaisance et professionnelle. La production **ULTRAFLEX** est depuis toujours une garantie de grande fiabilité et sécurité.

Tous les produits **ULTRAFLEX** sont conçus et fabriqués pour assurer toujours les meilleures performances les meilleures.

Pour assurer votre sécurité et pour maintenir toujours un niveau de qualité élevé **ULTRAFLEX** ne garantit ses produits que si les pièces de rechange originales sont utilisées (voir annexe "Application Spare Parts").

Les Systèmes de Assurance de la Qualité **ULTRAFLEX** et **UFLEX** sont certifiés par le Det Norske Veritas - Germanischer Lloyd (DNV-GL), en conformité avec la Norme UNI EN ISO 9001:2015.

Le système Qualité implique toutes les ressources et les processus d'entreprise à partir de la conception du projet au but de:

- assurer au client final la qualité du produit;
- maintenir et améliorer continuellement les standards de qualité ;
- poursuivre une constante amélioration de l'efficacité des processus afin de répondre toujours aux exigences du marché ainsi que d'augmenter la satisfaction des Clients;

Le système de Gestion Environnementale de la Qualité **ULTRAFLEX** est certifié par le Det Norske Veritas -Germanischer Lloyd (DNV-GL), en conformité avec la Norme UNI EN ISO 14001:2015.

Vérifier la conformité des produits aux prescriptions de la directive 2013/53/EU.



"**ULTRAFLEX**, avec plus de 85 années d'expérience dans le nautisme, est aujourd'hui une industrie de pointe sur scène mondiale dans la production de systèmes de gouvernail mécaniques, hydrauliques, électroniques, manettes et volants pour bateaux moteur de toutes dimensions pour la plaisance, la pêche ou le professionnel.

La fiabilité de nos produits et le service commercial et après-vente, la qualité de l'organisation de l'entreprise et des ressources humaines aussi bien que les investissements continus dans la recherche et le développement sont des facteurs fondamentaux pour expliquer le succès croissant de nos produits dans le monde entier.

ULTRAFLEX S.p.A.

16015 Casella (Genova) Italia - Via Crose, 2

INDEX

EMPLOI DU MANUEL ET SYMBOLES UTILISES	48
LETTRE D'INFORMATION	49
GARANTIE	49

SECTION 1 - DESCRIPTION DU PRODUIT

1.1 DESCRIPTION DU PRODUIT ET RECOMMANDATIONS D'EMPLOI	50
1.2 DIMENSIONS	51

SECTION 2 - TRANSPORT

2.1 AVERTISSEMENTS GENERAUX	52
2.2 CONTENU EMBALLAGE	52

SECTION 3 - INSTALLATION

3.1 OUTILS NECESSAIRES	54
3.2 INSTALLATION DE LA BOITE DE COMMANDE	54
3.2.1 VERSION MANETTE SANS COUPE-CIRCUIT	55
3.2.2 VERSION MANETTE AVEC COUPE-CIRCUIT	56
3.3 CONNEXION ELECTRIQUE COUPE-CIRCUIT	57
3.4 INSTALLTION DE L'INTERRUPTEUR DE SECURITE NEUTRE (OPTION)	58
3.5 INSTALLATION DE L'INTERRUPTEUR DE SECURITE NEUTRE + TILT (OPTION)	59
3.6 ASSEMBLAGE DU CABLE INVERSEUR	60
3.6.1 CONNEXION DU CABLE INVERSEUR AU CHASSIS	60
3.6.2 CONNEXION DU CABLE INVERSEUR AU BALANCIER	61
3.7 ASSEMBLAGE DU CABLE ACCELERATEUR	62
3.7.1 CONNEXION DU CABLE ACCELERATEUR AU BALANCIER	62
3.8 ASSEMBLAGE GROUPE MANETTE-MECANISME	63
3.9 REGLAGE DE LA FRICTION	63
3.10 INSTALLATION CABLES TRIM	63

SECTION 4 - EMPLOI DE LA MANETTE

4.1 EMPLOI DE LA MANETTE	64
4.2 ACCELERATION AU POINT MORT	64
4.3 FONCTIONNEMENT DU TRIM	64

SECTION 5 - AVERTISSEMENTS DE SECURITE

5.1 NORMES DE SECURITE PENDANT L'INSTALLATION ET L'EMPLOI	65
5.2 HABILLEMENT	65

SECTION 6 - ENTRETIEN

6.1 ENTRETIEN ORDINAIRE	65
6.2 ENTRETIEN EXTRAORDINAIRE	66

SECTION 7 - DEMOLITION

7.1 DEMOLITION	66
----------------------	----

EMPLOI DU MANUEL ET SYMBOLES UTILISES

Le MANUEL D'INSTALLATION ET D'ENTRETIEN est le document qui accompagne le produit de sa vente jusqu' son remplacement et sa d molition. C'est donc une partie fondamentale du manuel lui-m me. Il faut lire le manuel avant TOUTE ACTIVITE concernant le produit y compris sa manutention et son d chargement du moyen de transport.

Les symboles ci-dessous ont t adopt s dans le manuel afin d'assurer la s curit de l'usager et le fonctionnement correct du produit.

⚠ DANGER



Dommmages imm diats qui CAUSENT des blessures graves la personne ou bien qui en provoquent la mort.

⚠ AVERTISSEMENT



Il indique qu'il y a un danger qui peut provoquer des l sions ou la mort si on n'adoptent pas les pr cautions appropri es.

⚠ ATTENTION



Il indique un appel l'application de pratiques de s curit ou il appelle l'attention sur des pratiques non s res qui pourraient causer des l sions personnelles ou des dommages au bateau ou aux composants ou l'environnement.

NOTE



Information importante pour une installation ad quate et pour l'entretien, qui ne cause pas de dommages.



Les op rations pour l'ex cution desquelles on demande du personnel qualifi ou sp cialis , afin d'viter toute sorte de risques, sont indiqu es avec le symbole ct . On recommande de former le personnel pr pos l'installation du produit et de v rifier si ce qui est pr vu a t compris et mis en œuvr.

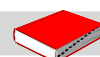
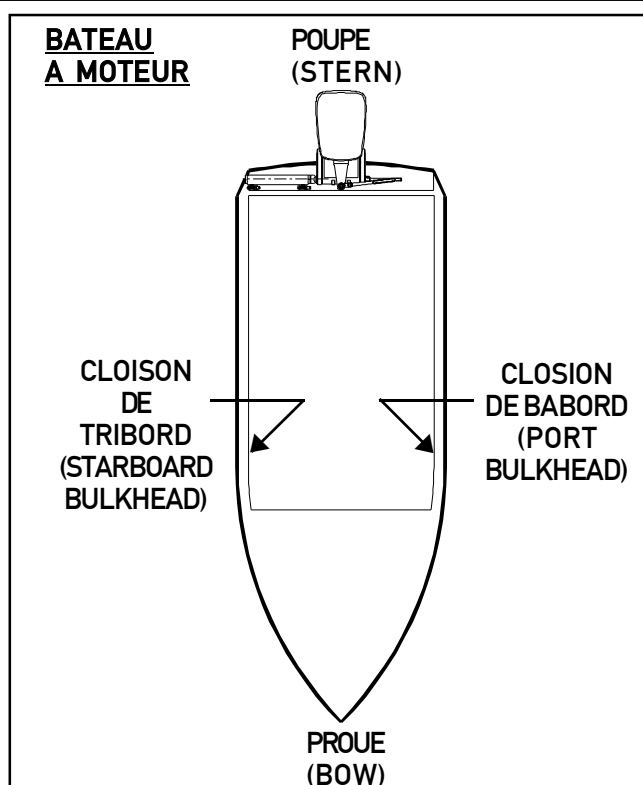

LETTRÉ D'INFORMATION

Ce manuel d'installation et d'entretien est une partie intégrante du produit et il doit être facilement repérable par le personnel responsable de son emploi et son entretien.

L'utilisateur doit connaître le contenu de ce manuel. La Société **ULTRAFLEX** décline toute responsabilité en cas d'inexactitudes dues à des fautes d'impression, contenues dans le manuel. Bien que les caractéristiques principales du type de produit décrit ne changent pas, la Société **ULTRAFLEX** se réserve le droit de modifier les descriptions, les détails et les illustrations qu'elle jugera nécessaires afin de l'améliorer, soit pour des exigences de caractère constructif ou commercial, dans n'importe quel moment et sans être obligé de mettre à jour le manuel tout de suite. **TOUS LES DROITS SONT RÉSERVÉS**. Les droits de publication, les marques, les sigles et les photos des produits **ULTRAFLEX** contenus dans ce manuel appartiennent à la Société **ULTRAFLEX** qui en interdit toute sorte de reproduction même partielle. Tous les soins ont été pris pour rassembler et contrôler la documentation contenue dans ce manuel afin de le rendre le plus complet et le plus compréhensible possible. Rien de ce qui est contenu dans cette publication ne peut être interprété comme garantie ou condition explicite ou implicite - y compris, pas en voie limitative, la garantie d'aptitude pour un but particulier. Rien de ce qui est contenu dans cette publication ne peut être interprété comme modification ou assertion des termes de n'importe quel contrat d'achat.

AVERTISSEMENT

Le produit doit être installé par du personnel formé afin d'assurer son fonctionnement correct et celui de ses composants. En cas de rupture de parties ou de mauvais fonctionnement, s'adresser au personnel spécialisé ou contacter notre Service d'Assistance Technique.

SERVICE ASSISTANCE TECHNIQUE

UFLEX S.r.l.

Via Milite Ignoto,8A
16012 Busalla (GE)-Italia
Tél: +39.010.962.01
Email: service@ultraflexgroup.it
www.ultraflexgroup.it

Amérique du nord - du sud - centrale:
UFLEX USA

6442 Parkland Drive
Sarasota, FL 34243
Tél: +1.941.351.2628
Email: sales@uflexusa.com
www.uflexusa.com

GARANTIE

La Société **ULTRAFLEX** garantit que ses produits sont fabriqués soigneusement et qu'ils n'ont aucun défaut de fabrication et de matériaux.

Cette garantie a une validité de deux ans à partir de la date de fabrication des produits à l'exception des cas où ils sont installés et utilisés sur des bateaux de travail ou de commerce, car alors la garantie est limitée à une année de la date de fabrication.

Dans le cas où, pendant cette période le produit s'avérerait défectueux à cause des matériaux utilisés ou/et présente des vices de fabrication, le fabricant le remplacera ou le réparera gratuitement.

Tout autre dommage direct ou indirect est exclu de la garantie. En particulier la Société constructrice n'est pas responsable et cette garantie ne couvre pas les dommages résultant d'une installation incorrecte ou d'un emploi inadéquat ou abusif des produits (à l'exception du remplacement ou de la réparation des pièces défectueuses dans les termes et les délais susmentionnés).

Cette garantie ne couvre pas les produits installés sur des bateaux de course ou utilisés pour des compétitions. Les descriptions et les illustrations contenues dans ce manuel sont seulement à titre indicatif.

Pour toute information détaillée contacter notre Service d'Assistance.

Les composants des systèmes de conduite **ULTRAFLEX** sont pourvus de la marque  en conformité avec la directive 2013/53/UE.

On rappelle que sur les bateaux pourvus de la marque CE il est obligatoire d'installer des systèmes de conduite dont les composants sont marqués CE. Nous vous informons que la garantie **ULTRAFLEX** choisit automatiquement au cas où certains composants **ULTRAFLEX** seraient installés dans un système de gouvernail avec des produits de marques différentes.



1 DESCRIPTION DU PRODUIT

1.1 Description du produit et recommandations d'emploi

La commande mono-manette doit être assemblée sur un c t de la console principale du bateau. La manette est quip e de friction r glable, de dispositif bouton pour actionner le gaz avec l'inverseur au point mort et de bouton pour le r glage du trim.

La commande mono-manette **B110** est pourvue d'un kit standard pour l'emploi de la manette avec les c bles suivants **ULTRAFLEX**:

- **C2 - C8 - MACHZero** (c bles classe 33C);

Si le Client doit assembler la manette sur des moteurs qui n cessitent l'emploi de c bles d'un autre type par rapport ceux indiqu s ci-dessus, il faut utiliser un kit sp cifique (option) pour les installer comme d crit ci-dessous:

KIT K74: c bles C5 et MACH5 (Mercury® GEN I)

KIT K75: c bles C36 et MACH36 (Mercury® GEN II)

KIT K76: c bles C14 (OMC®, EVINRUDE®)

Dans ce cas, ne pas utiliser le kit standard fourni.

ATTENTION

Si on utilise un kit optionnel, suivre les instructions fournies avec le kit lui-m me.

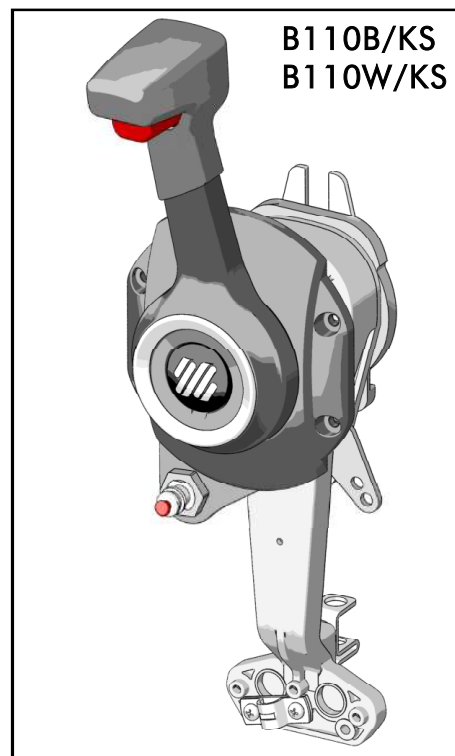
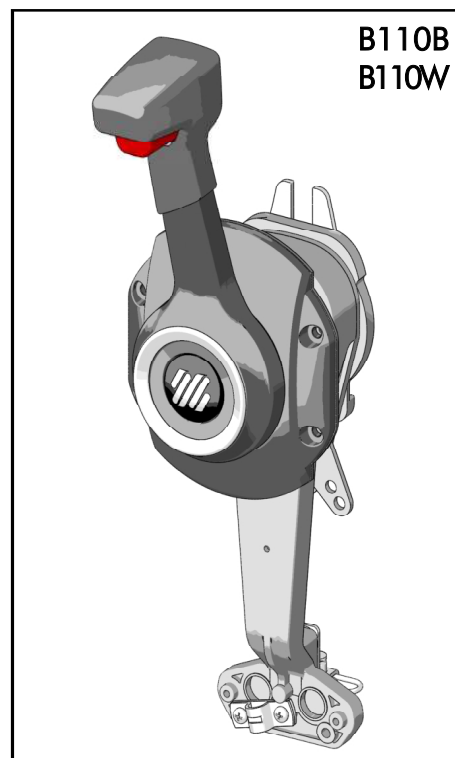

1.2 Dimensions

Les figures suivantes indiquent les dimensions des quatre modèles des commandes mono-manette B110.

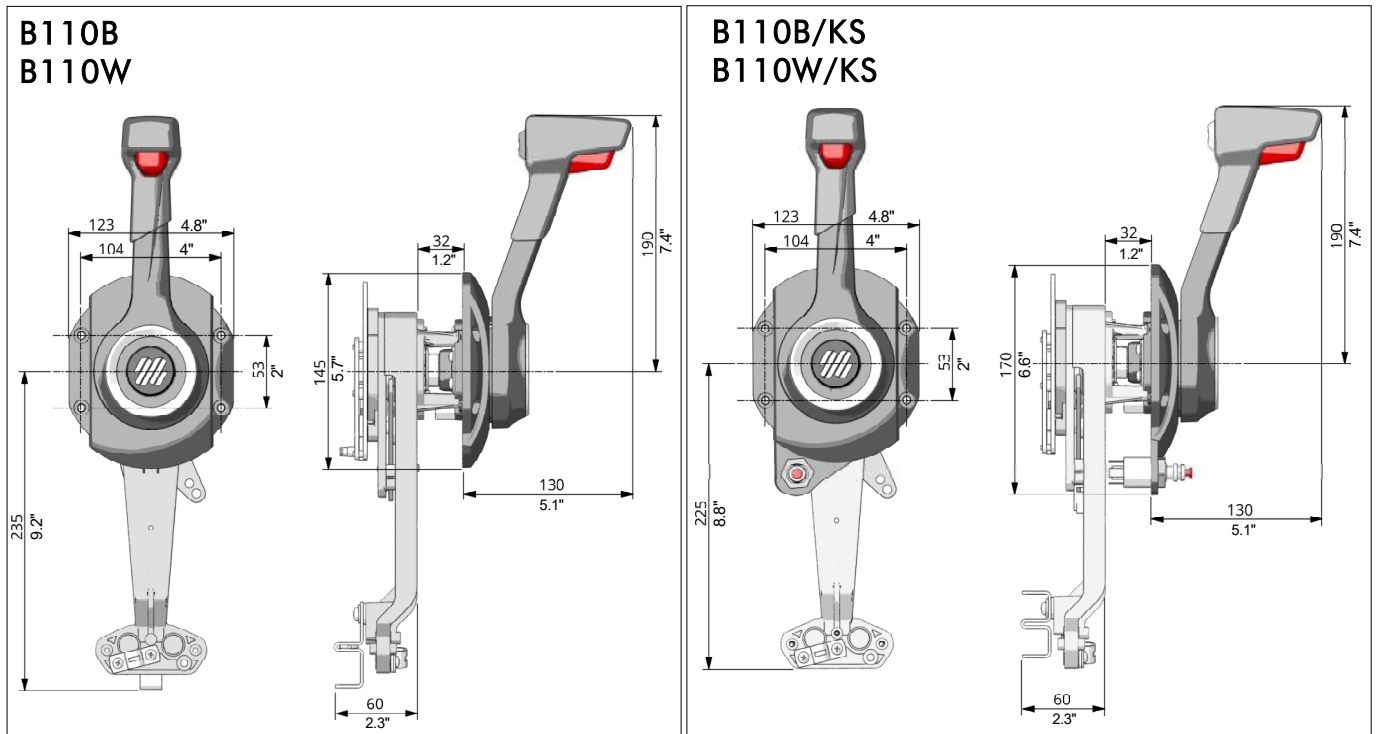

DIMENSIONS D'ENCOMBREMENT MINIMUM POUR LA ROTATION DES MANETTES

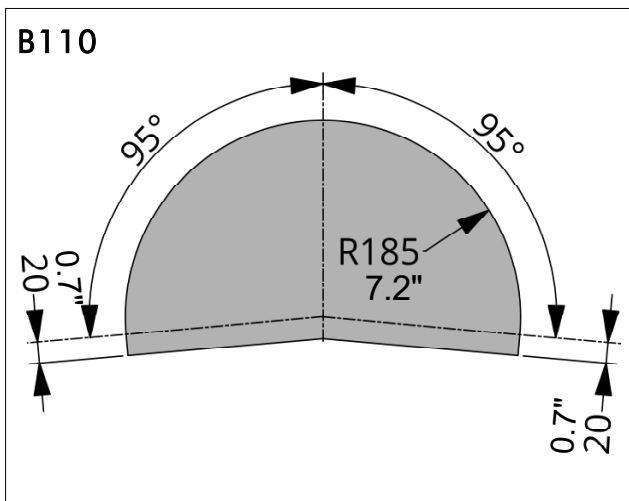

NOTE

S'assurer que la manette puisse tourner librement et que sa course ne soit pas bloquée.



2 TRANSPORT

2.1 Avertissements généraux

Le poids du produit avec son emballage est d'environ 2,5Kg (5,5 livres), il peut donc être manipulé manuellement.

⚠ AVERTISSEMENT

Le personnel chargé de la manipulation de l'installation doit porter des gants de protection et des chaussures de sécurité.

2.2 Contenu emballage

Avant de commencer l'installation de l'appareillage s'assurer qu'il ne soit pas endommagé à cause du transport ou des conditions de conservation. Vérifier aussi que tous les composants faisant partie de l'équipement standard soient dans l'emballage (voir liste). En cas d'endommagement, notifier la réclamation au transporteur et informer votre fournisseur.

Contenu des emballages des boîtes de commande:

REF	COMPOSANT
A	boîte de commande
A1	bride
A2	joint
A3	manette
A4	bouton

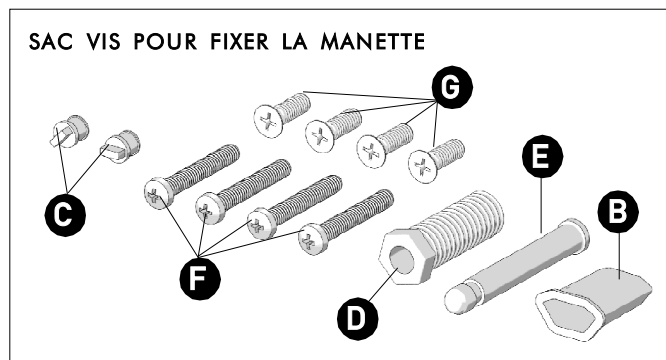
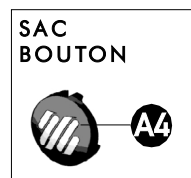
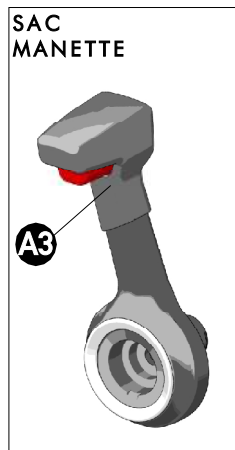
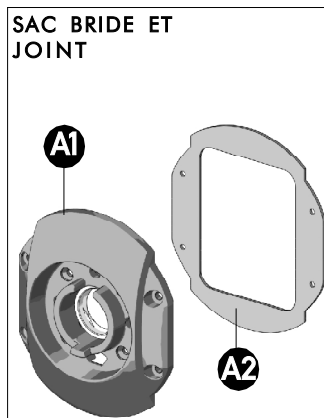
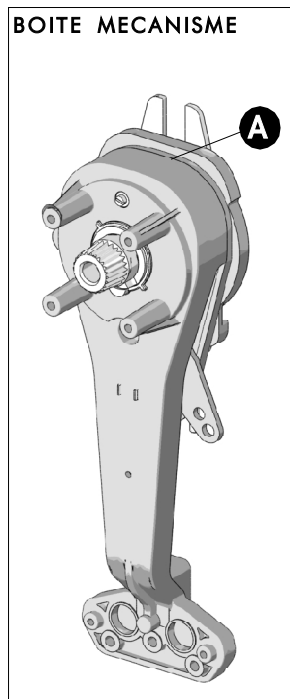

REF	COMPOSANT
B	joint en caoutchouc pour passe-cables
C	bouchon
D	vis de fixation levier
E	pivot
F	vis de fixation bride
G	vis de fixation mécanisme

FRANÇAIS



SAC PETITS COMPOSANTS POUR LES CABLES C2 - C8 - MACHZero

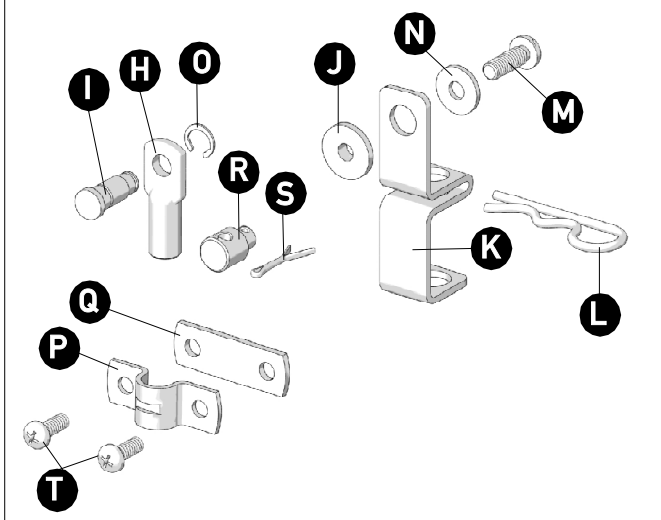

REF	COMPOSANT
H	terminaison de c ble acc l rateur
I	pivot d'arr t c ble
J	douille d'arr t gaine
K	joint
L	goupille lastique
M	vis
N	rondelle
O	seeger
P	cavalier
Q	plaque
R	terminaison c ble
S	goupille
T	vis

Si la manette est pourvue de coupe-circuit (mod les B110B/KS et B110W/KS), un autre kit sera fourni (en addition ceux d crits la page pr c dente) compos de la corde avec le clip de fixation, de l' crou et du coupe-circuit lui-m me.

Ces composants seront fournis dans un seul sac.

SAC COMPOSANT POUR MANETTE POURVUE DE COUPE-CIRCUIT

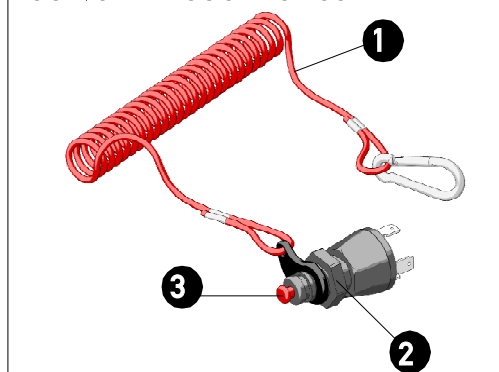

REF	COMPOSANT
1	corde avec clip de fixation
2	crou
3	coupe-circuit

NOTE

Pour installer correctement le coupe-circuit, consulter le paragraphe 3.2.2.

ATTENTION

Les emballages doivent tre limin s selon les normes en vigueur.



3 INSTALLATION

3.1 Outils nécessaires



Tournevis
toilé)



Tournevis plat
(Ø2)



Pince



Clamp
14 mm



Perceuse

3.2 Installation de la boîte de commande



NOTE

Selon les cibles de commande, il est possible d'ASSEMBLER le mécanisme en position horizontale ou verticale comme indiqué dans les figures ci-dessous, en faisant tourner le mécanisme interne de manière à faire correspondre le trou d'inspection de la bride avec la vis de réglage de l'embrayage du mécanisme (voir par. 3.9). Cette considération est également valable pour les modèles manettes pourvues de coupe-circuit.

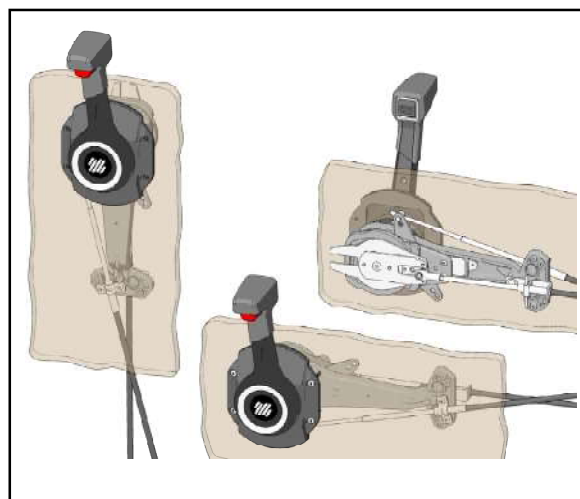

⚠ ATTENTION

Utiliser les bouchons "C" fournis dans le sac des vis pour fermer deux des trois trous d'inspection inutilisés dans la bride. Cette considération est également valable pour les modèles manette pourvue de coupe-circuit.

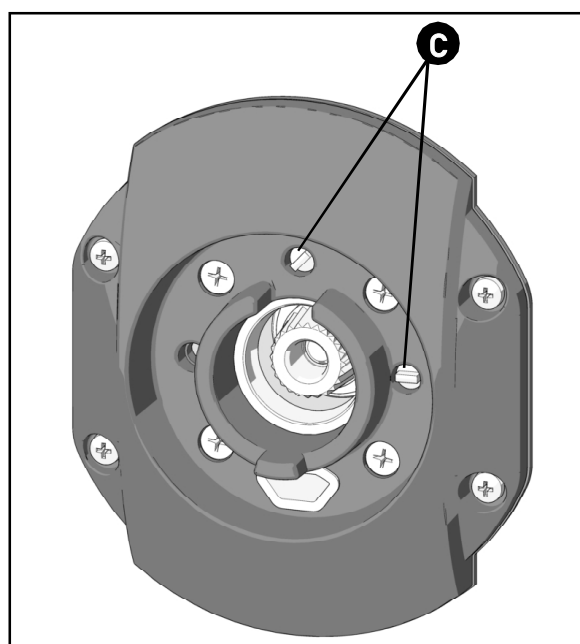

3.2.1 Version manette sans coupe-circuit

⚠ ATTENTION

Ne pas plier trop les câbles (rayon minimum: 200 mm - 8"). On recommande d'utiliser des câbles **ULTRAFLEX**.

1 Consulter les dimensions indiquées au paragraphe 1.2 pour vérifier que la boîte puisse effectivement être installée dans la position choisie.

2 Après avoir déterminé la position appropriée, effectuer le perçage nécessaire pour insérer la boîte de commande à l'aide du gabarit approprié (joint). L'épaisseur de la surface d'installation de la manette ne doit pas être supérieure à 20 mm (0.7").

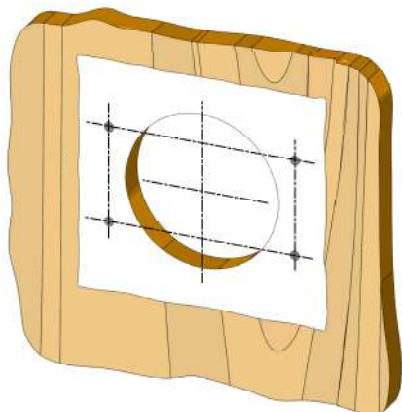

3 Fixer la bride (A1) et le joint relatif (A2) à l'aide des vis (F).

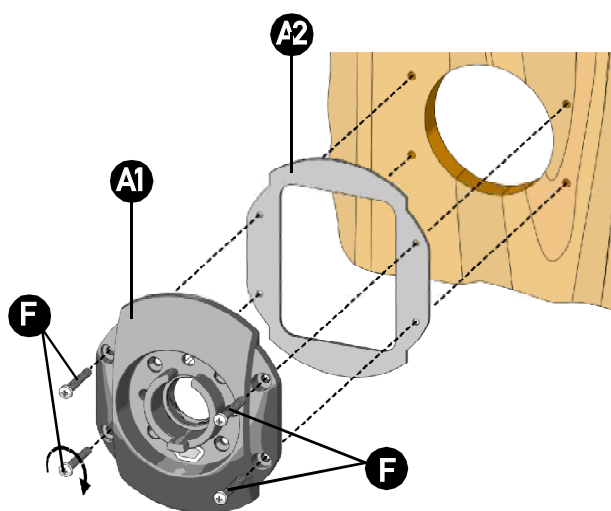

4 Fixer le mécanisme de la boîte de commande (A) à la bride (A1) à l'aide des vis (G).

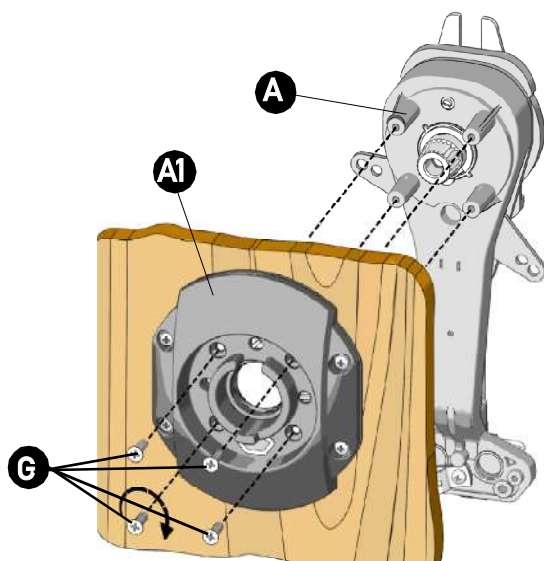

NOTE

Les câbles d'accélérateur et d'inverseur doivent ensuite être connectés au chassis et aux balanciers selon les instructions des chapitres 3.6 et 3.7.



3.2.2 Version manette avec coupe-circuit

⚠ ATTENTION

Ne pas plier trop les câbles (rayon minimum: 200 mm - 8 "). On recommande d'utiliser des câbles ULTRAFLEX.

1 Consulter les dimensions indiquées au paragraphe 1.2 pour vérifier que la boîte puisse effectivement être installée dans la position choisie.

2 Après avoir déterminé la position appropriée, effectuer le perçage nécessaire pour insérer la boîte de commande à l'aide du gabarit approprié (joint). L'épaisseur de la surface d'installation de la manette ne doit pas être supérieure à 20 mm (0,7 ").

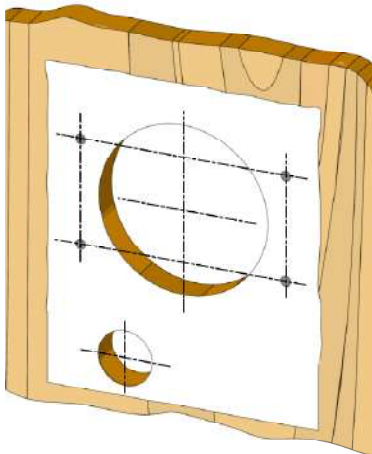

3 À l'aide de l'écrou (2) visser l'interrupteur (1) au groupe composé de la bride (A1) et du joint (A2).

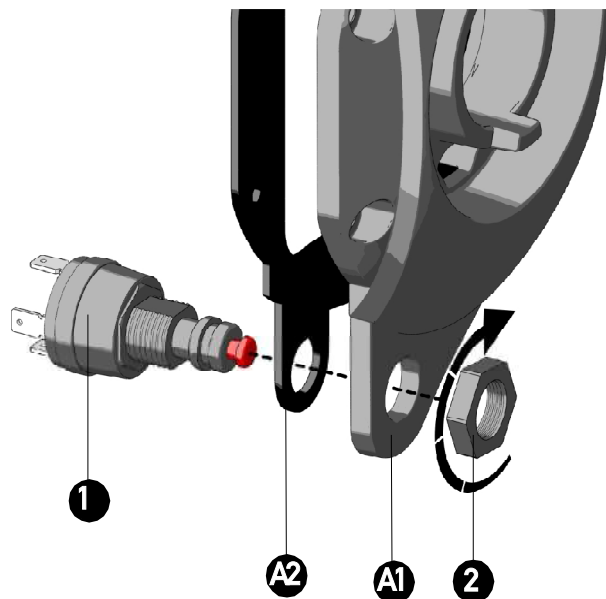

4 Fixer la bride (A1) et le joint relatif (A2) à l'aide des vis (F).

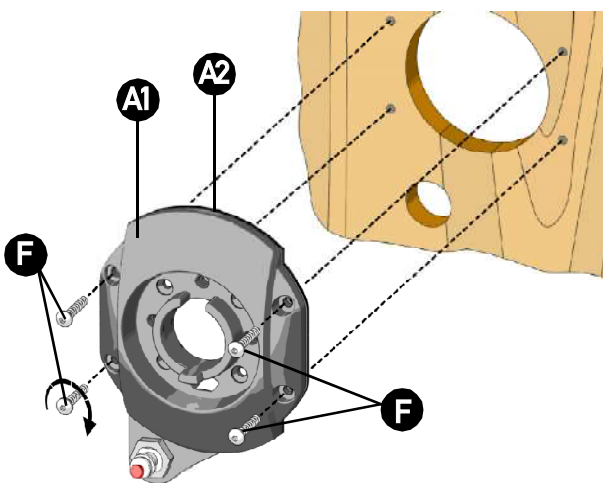

5 Fixer le mécanisme de la boîte de commande (A) à la bride (A1) à l'aide des vis (G).

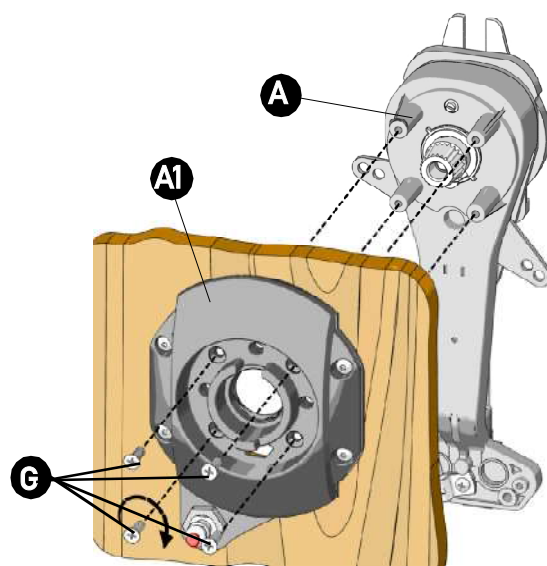

3.3 Connexion électrique coupe-circuit



⚠ AVERTISSEMENT

Pour connecter correctement l'interrupteur, il faut consulter le schéma graphique de câblage indiqué ci-dessous. L'utilisateur doit en tout cas effectuer les connexions en considérant le type de système électrique présent dans le bateau.

⚠ AVERTISSEMENT

Une mauvaise installation de l'interrupteur peut causer des blessures graves, voire mortelles.

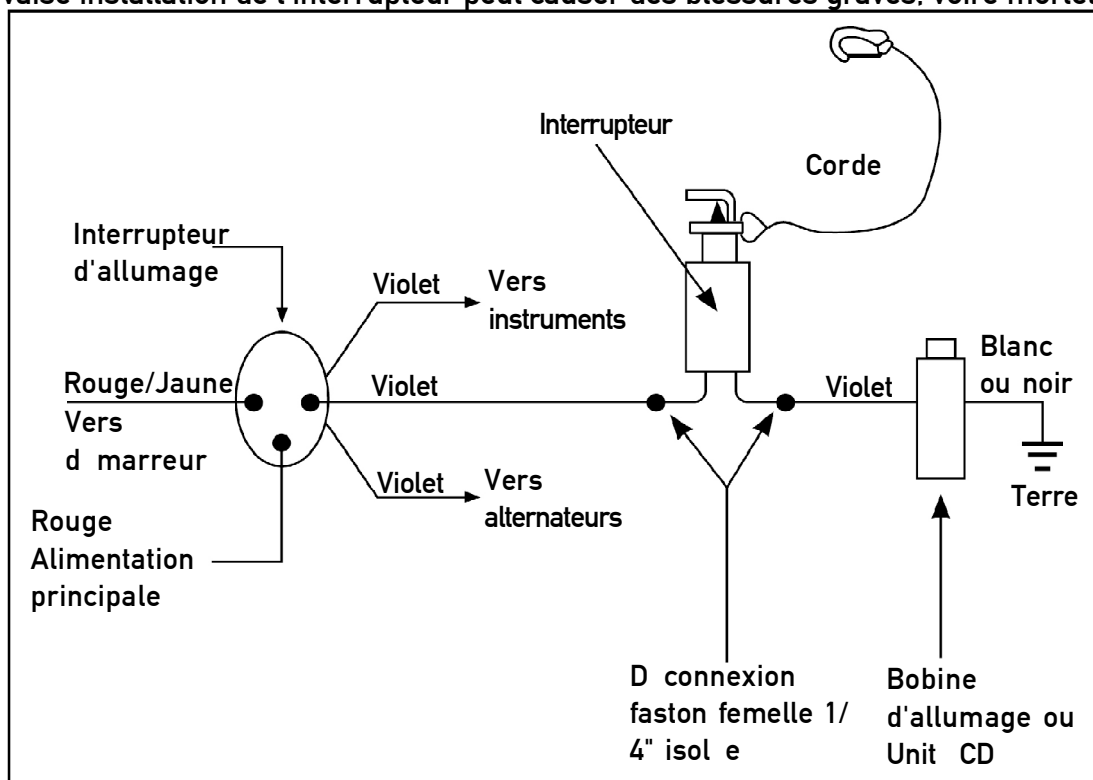

L'interrupteur est pourvu d'un clip avec une corde qui tient le piston de l'interrupteur dans une position pour assurer le fonctionnement du moteur. La corde, au moyen du clip, est connectée à l'opérateur en toute sécurité. Si l'opérateur s'éloigne des commandes, le clip se détache en libérant le piston et en arrêtant le moteur.

Pour que le coupe-circuit fonctionne correctement, procéder comme suit:

- 1) avant de démarrer le moteur, vérifier que le clip de fixation de la corde soit correctement positionné sur l'interrupteur et qu'il puisse tourner librement.
- 2) vérifier l'état de la corde: si elle est coupée, usée ou effilochée, la remplacer.
- 3) démarrer le moteur.
- 4) essayer l'interrupteur en débranchant le clip de fixation de la corde elle-même: le moteur doit s'arrêter.

⚠ AVERTISSEMENT

Si le moteur ne s'arrête pas, vérifier l'ensemble du câblage.

Si le moteur ne démarre pas, ne s'arrête pas ou fonctionne avec le clip de la corde détaché, contacter votre revendeur local de fournitures marines pour obtenir de l'assistance.

⚠ AVERTISSEMENT

Il est interdit de changer la longueur de la corde ou d'utiliser la corde fournie par un autre fabricant avec cet interrupteur; cela peut compromettre son bon fonctionnement.

Une utilisation incorrecte, des modifications non autorisées ou une installation incorrecte de ce dispositif de sécurité peuvent entraîner des blessures graves, voire mortelles.



3.4 Installation de l'interrupteur de sécurité neutre (option)



Ce dispositif (option) permet de démarrer le moteur uniquement avec la manette en position "neutral", évitant les mouvements intempestifs du bateau.

Pour l'assemblage, procéder comme indiqué ci-dessous :

Fixer l'interrupteur de sécurité X41 au moyen de la vis (1), la rondelle (2) et l'écrou (3) (inclus dans le kit X41), comme indiqué dans la figure.

NOTE

La tête de la vis doit appuyer sur la surface de l'interrupteur.

Pour un fonctionnement correct de l'interrupteur de sécurité neutre X41, effectuer les opérations suivantes :

- 1) avant de démarrer le moteur, vérifier que l'interrupteur soit installé correctement.
- 2) déplacer la manette en avant et en arrière (en passant de la position NEUTRAL) et vérifier que l'interrupteur commute.
- 3) contrôler l'interrupteur en faisant beaucoup d'attention aux schémas de câblage et aux connexions.
- 4) démarrer le moteur et vérifier que le système fonctionne correctement.

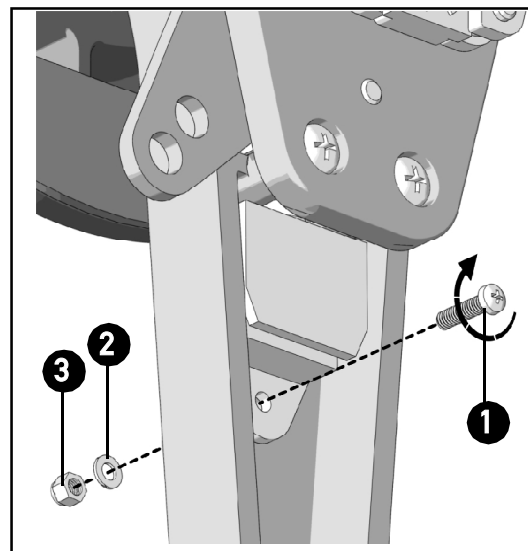
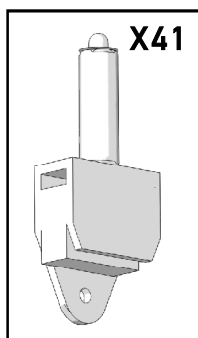

ATTENTION

Lorsque la manette est en position NEUTRAL, le circuit doit être fermé ; lorsqu'elle est dans une position différente, le circuit doit être ouvert.

AVERTISSEMENT

Si le moteur doit démarrer même quand la manette n'est pas en position NEUTRAL, vérifier l'ensemble de câblage. Une utilisation incorrecte, des modifications non autorisées ou une installation incorrecte de cet interrupteur de sécurité neutre peuvent causer des blessures graves, voire mortelles.



3.5 Installation de l'interrupteur de sécurité neutre+ tilt (option)



Ce dispositif (option) permet de démarrer le moteur uniquement avec la manette en position "neutral", évitant les mouvements intempestifs du bateau et en même temps, l'aide de l'interrupteur sur la manette, il permet de contrôler l'inclinaison du moteur.

Pour l'assemblage, procéder comme indiqué ci-dessous :

Fixer l'interrupteur de sécurité X48 au moyen de la vis (1), la rondelle (2) et l'écrou (3) (inclus dans le kit X48), comme indiqué dans la figure.

NOTE

La tête de la vis doit appuyer sur la surface de l'interrupteur.

Pour un fonctionnement correct de l'interrupteur de sécurité neutre X48, effectuer les opérations suivantes :

- 1) avant de démarrer le moteur, vérifier que l'interrupteur soit installé correctement.
- 2) déplacer la manette en avant et en arrière (en passant de la position NEUTRAL) et vérifier que l'interrupteur commute.
- 3) contrôler l'interrupteur en faisant beaucoup d'attention aux schémas de câblage et aux connexions.
- 4) démarrer le moteur et vérifier que le système fonctionne correctement.

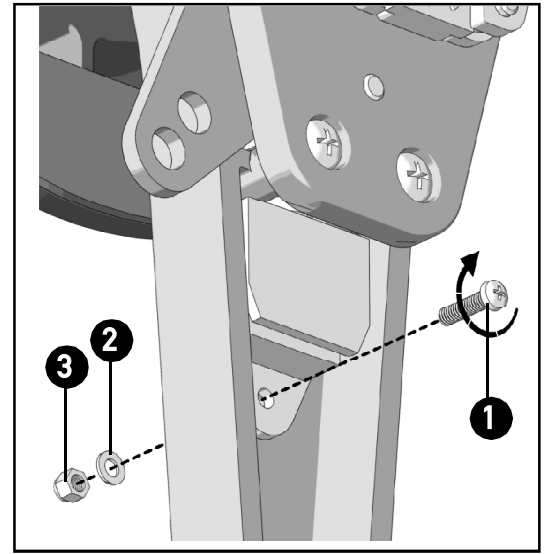
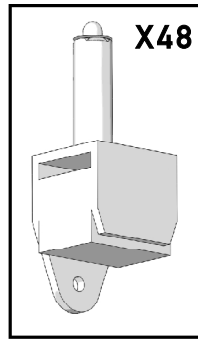

⚠ ATTENTION

Lorsque la manette est en position NEUTRAL, le circuit doit être fermé ; lorsqu'elle est dans une position différente, le circuit doit être ouvert.

⚠ AVERTISSEMENT

Si le moteur doit se démarrer même quand la manette n'est pas en position NEUTRAL, vérifier l'ensemble du câblage. Une utilisation incorrecte, des modifications non autorisées ou une installation incorrecte de cet interrupteur de sécurité neutre peuvent causer des blessures graves, voire mortelles.



3.6 Montage du câble inverseur



⚠ ATTENTION

Avant de commencer l'installation, s'assurer que le balancier de l'inverseur soit en position neutre (horizontale) et que l'accélérateur soit en position minimum (position indiquée dans la figure).

D'ici à la fin de l'installation, si le châssis il faudra installer le câble inverseur selon qu'un mouvement de traction ou de poussée du câble est requis.

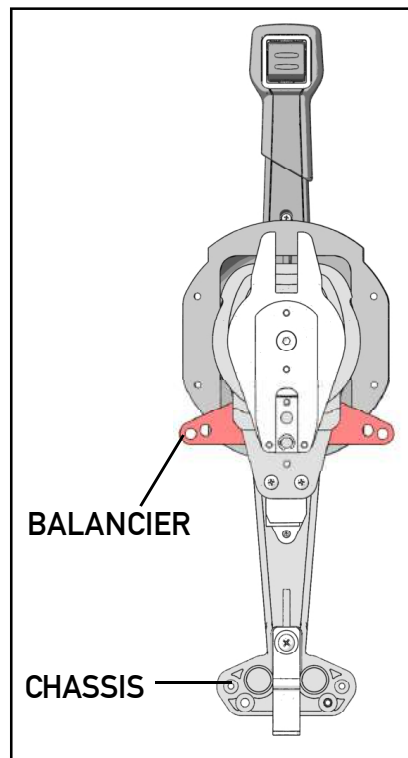

3.6.1 Connexion du câble inverseur au châssis

1 Fixer la partie terminale de la gaine du câble inverseur au châssis à l'aide de la plaque (Q) et le cavalier (P) au moyen des vis (T). ensuite serrer les vis.

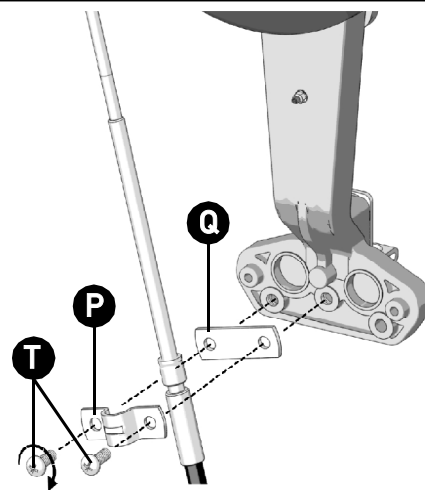

FRANÇAIS



3.6.2 Connexion du câble inverseur au balancier

1 Visser la terminaison de câble (R) sur le filetage latéral du câble inverseur. Fermer ou allonger le câble de façon à insérer la partie terminale dans le trou du balancier. Vérifier que le câble effectue tous les déplacements nécessaires. Si la course est correcte, serrer le contre-crou (1) et insérer la goupille appropriée (S) dans la partie terminale du câble pour l'empêcher de glisser du balancier. Si la course n'est pas celle souhaitée, visser ou dévisser la partie terminale sur le latéral du câble pour obtenir un réglage plus fin, ensuite serrer le contre-crou (1) et insérer la goupille adéquate (S) dans la partie terminale du câble.

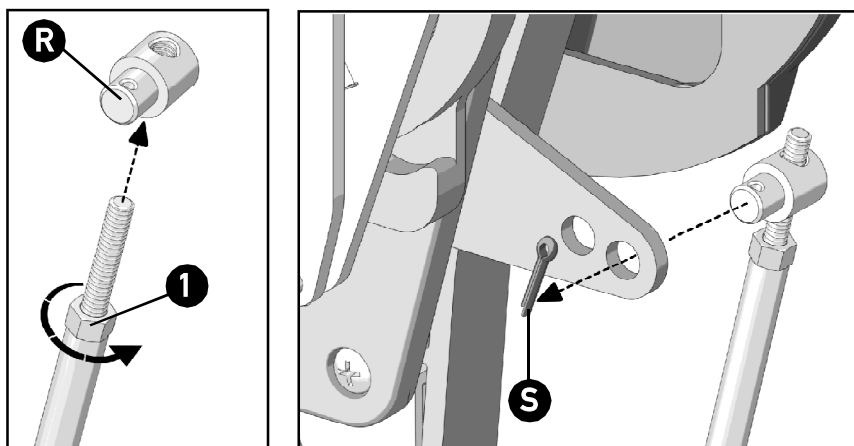

⚠ ATTENTION

- Le bon fonctionnement du mécanisme de commande dépend du réglage exact de la course de l'inverseur.

⚠ ATTENTION

En aucun cas, la course développée par la commande mono-manette (67 mm (2,64 ") sur le trou interne; 78 mm (3,0") sur le trou externe du balancier) ne doit être supérieure à la course mesurée sur la manette du moteur.

Cela pourrait endommager le câble et la commande.

- Les gaines de câbles, venant de la partie inférieure de la commande, peuvent être emballées en groupes ou fixées à une distance minimale de 500 mm (19,7 ") de la commande elle-même.





3.7 Montage du câble accélérateur

Les instructions pour la connexion du câble accélérateur sont indiquées ci-dessous.

1 Tourner la manette d'au moins 45° de manière à amener la glissière dans la partie inférieure du balancier dans une position permettant l'insertion de la goupille (voir figure). Insérer la goupille (I) dans le trou externe de la glissière de la partie inférieure du balancier vers la partie supérieure (voir figure) et la bloquer avec le seeger (O).

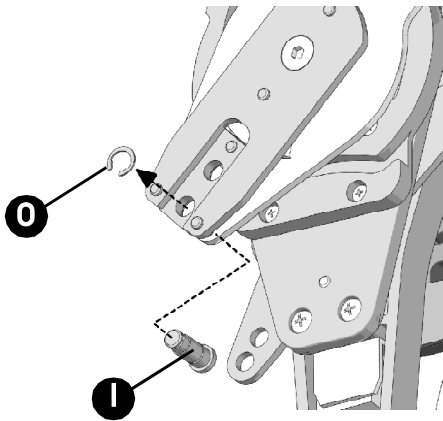

2 Fixer l'arrêt-gaine (K) au mécanisme à l'aide de la douille d'arrêt-gaine (J), la rondelle (N) et la vis (M). Insérer ensuite le câble dans l'arrêt-gaine (K), en s'assurant qu'il soit tourné vers l'extérieur, comme indiqué dans la figure. Le bloquer en insérant la goupille lastique (L) dans le siège au centre de l'arrêt-gaine.

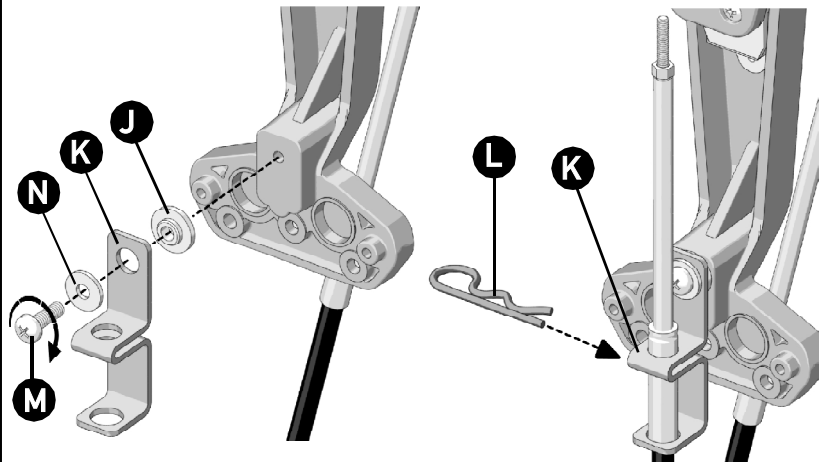

3.7.1 Connexion du câble accélérateur au balancier

1 Visser la partie terminale du câble (H) sur le filetage dans la tête au câble accélérateur.

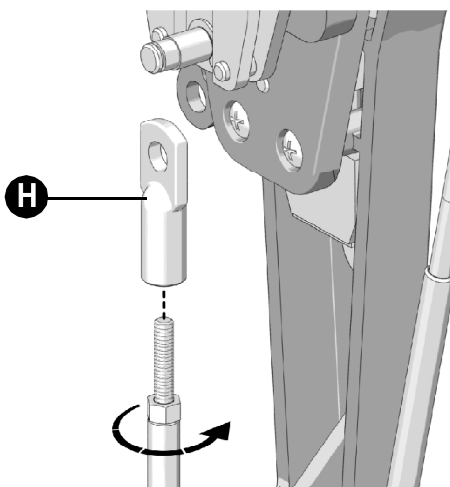

2 Insérer l'embout sur le pivot (I) et le fixer avec le seeger (O).

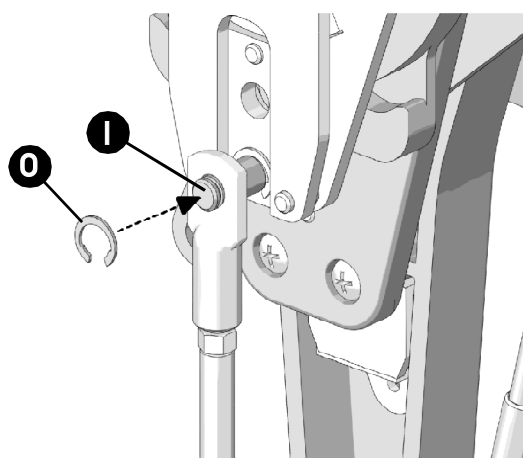

⚠ ATTENTION

- Le fonctionnement correct de la commande dépend du réglage exact de la course de l'accélérateur.



3.8 Montage groupe manette



1 Positionner le joint en caoutchouc pour passe-câbles (B) dans la fente présente dans la partie inférieure de la bride et insérer le câble du trim en sortie de la manette (A3) travers au joint en caoutchouc. En dirigeant les câbles vers le mécanisme, insérer la manette en position neutre (verticale) dans la boîte de commande sur l'arbre nervuré. Insérer la vis (D) pourvue de pivot (E) et la serrer à l'aide d'une clé de 14mm. Enfin, insérer le bouton (A4) dans son siège sur le moyeu de la manette, en pressant jusqu'à entendre le clic. Cette procédure est également valable pour les modèles manette avec coupe-circuit.

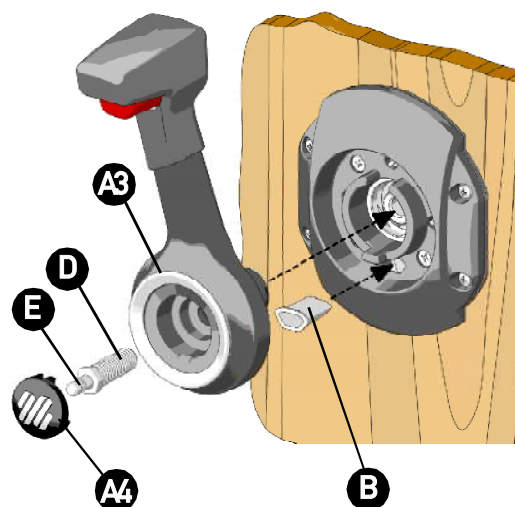

⚠ ATTENTION

Le joint en caoutchouc pour passe-câbles doit être installé car il protège les câbles contre tout endommagement.

3.9 Réglage de la friction



1 Accéder à la vis de réglage de la friction en agissant à l'aide d'un tournevis plat. Tourner la vis dans le sens des aiguilles d'une montre pour augmenter la friction, dans le sens contraire des aiguilles d'une montre pour le diminuer.

NOTE

LE REGLAGE DE LA FRICTION DOIT TOUJOURS ETRE EFFECTUE AVEC LE MOTEUR A L'ARRET, EN DESASSEMBLANT LA MANETTE DE SA POSITION.

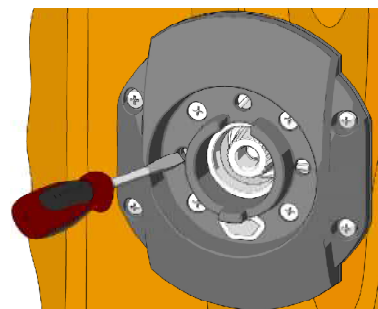

3.10 Installation câbles trim



Les TRIM permettent de modifier la position des moteurs en les soulevant ou en les abaissant. Le schéma indique comment connecter les trois fils: vert (moteur supérieur), rouge (commun) et blanc (moteur inférieur).

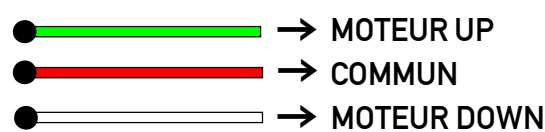

NOTE

Pour un fonctionnement correct du TRIM, effectuer les opérations suivantes:

- 1) avant de mettre le moteur en marche, vérifier que les câbles électriques du TRIM aient été correctement serrés sur le pied du mécanisme (en contrôlant qu'ils ne soient pas trop serrés, en laissant une longueur suffisante).
- 2) câbler le TRIM en faisant particulièrement attention aux schémas de câblage et aux connexions.
- 3) alimenter l'appareil et vérifier que le système fonctionne correctement.

⚠ AVERTISSEMENT

Ne pas modifier toute partie de cet interrupteur, car cela pourrait compromettre le bon fonctionnement. Une utilisation incorrecte, des modifications non autorisées ou une installation inadéquante de ce dispositif de sécurité peuvent causer des blessures graves, voire mortelles aux personnes.

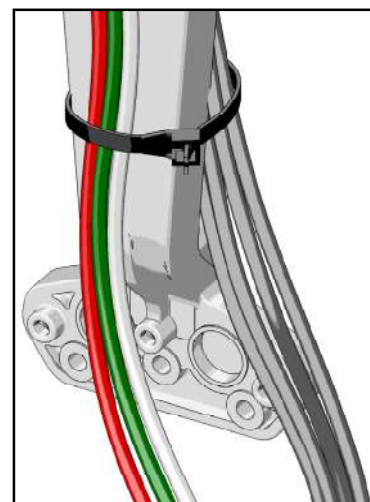

4 EMPLOI DE LA MANETTE

4.1 Emploi de la manette

La manette est tenu en position neutre (verticale); pour le d bloquer, il faut appuyer sur la g chette situ e sous la poign e. La course de la manette est divis e en deux mouvements: dans la premi re phase de 30° l'inverseur est activ , dans les phases suivantes de 65° l'acc l rateur est activ . En d plaçant la manette en avant, le bateau avance. tandis qu'en arri re on proc de dans le sens inverse.

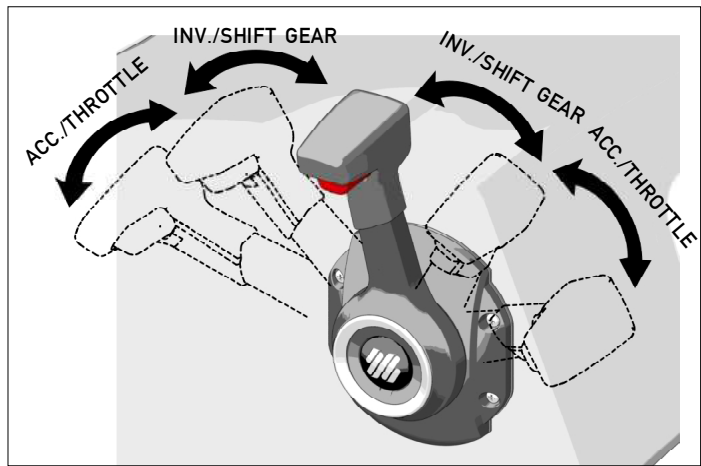

⚠ DANGER

Avant de d marrer le moteur, si la commande n'a pas de safety switch, s'assurer qu'il soit en position de point mort.



4.2 Accélération au point mort

Appuyer sur le bouton central et, en le tenant press , tourner la mono-manette dans le sens des aiguilles d'une montre ou dans le sens contraire des aiguilles d'une montre jusqu' obtenir le nombre de tours souhait . En repositionnant la manette au point mort, le ressort de rappel ram nera le bouton dans sa position initiale.

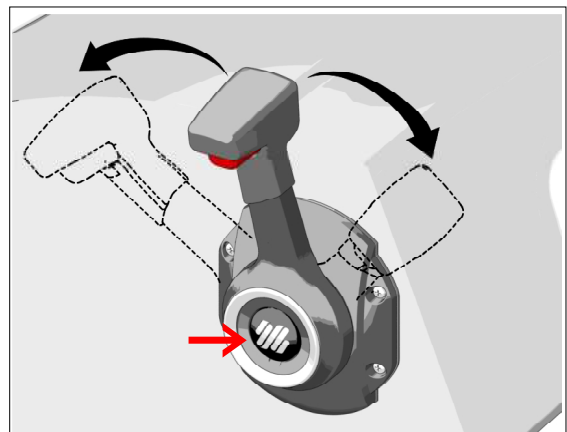

4.3 Fonctionnement du trim

Le trim permet de varier l'assiette du bateau en mouvement en agissant sur l'inclinaison des moteurs.

⚠ AVERTISSEMENT

Si l'utilisateur a achet l'interrupteur de s curit neutre + inclinaison en option (kit X48), il est n cessaire de consulter les instructions d'installation et de fonctionnement correspondantes d crites au paragraphe 3.5.

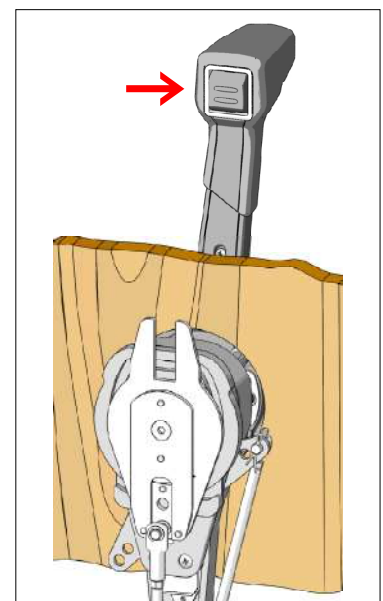

5 AVERTISSEMENTS DE SECURITE

Cette section décrit les normes de sécurité à suivre pour utiliser correctement l'appareillage. On recommande de lire cette section avec beaucoup d'attention. On recommande aussi de lire les manuels fournis avec les autres composants de la commande mono-manette.

5.1 Normes de sécurité pendant l'installation et l'emploi

RESPECTER RIGOREUSEMENT les précautions et les critères de sécurité indiqués ci-dessous.

La Société **ULTRAFLEX** décline toute responsabilité au cas où l'utilisateur ne les respecterait pas; elle n'est pas non plus responsable pour tout type de négligence commise pendant l'emploi du système.

DANGER

- **NE PAS INSERER LES MAINS ENTRE LES ORGANES EN MOUVEMENT.**
- Ne pas désactiver ou déconnecter les dispositifs de sécurité.
- Ne pas modifier ou ajouter n'importe quel dispositif au système, sans autorisation écrite ou intervention technique de la Société **ULTRAFLEX** qui atteste dans la description de l'intervention la modification effectuée.
- Ne pas utiliser l'appareillage pour un but différent de celui auquel il a été destiné et qui est spécifié dans le manuel d'installation et d'entretien.
- Ne pas faire exécuter l'installation par du personnel non spécialisé.

AVERTISSEMENT

- Pendant l'installation du système faire très attention à nettoyer soigneusement afin d'éviter que n'importe quel corps étranger puisse entrer dans le système lui-même. Même l'objet le plus petit pourrait provoquer des dommages permanents qui ne sont pas détectés immédiatement.
- Éviter tout rayon de courbure des câbles <math>< 200 \text{ mm}</math> (8").
- Éviter le contact des câbles avec des bords ou des arêtes de coupe.
- Éviter le contact des câbles avec les sources de chaleur.

5.2 Habillement

AVERTISSEMENT

Pendant les phases d'installation, inspection ou entretien, IL EST RIGOREUSEMENT INTERDIT de porter de colliers, de bracelets ou de vêtements qui pourraient s'engager dans les parties en mouvement.

6 ENTRETIEN

6.1 Entretien ordinaire

AVERTISSEMENT

La non-observation des contrôles d'entretien peut causer la perte de guidage avec des dommages matériels et/ou des lésions personnelles.

Les conditions requises pour l'entretien varient selon le climat, la fréquence et le mode d'emploi. Des inspections au moins annuelles sont nécessaires; elles doivent être effectuées par un mécanicien nautique spécialisé. Effectuer les opérations d'entretien suivantes:

- Périodiquement laver avec de l'eau et du savon les composants en enlevant tout dépôt de sel ventuel;
- Tous les mois contrôler et si nécessaire serrer tous les écrous de fixation du système.

⚠ DANGER

Le desserrage ou la séparation des écrous de fixation peut causer non seulement le mauvais fonctionnement de la commande mono-manette, mais aussi des dommages aux personnes et aux choses.

- Périodiquement vérifier l'absence de corrosion sur les parties métalliques des extrémités des câbles et d'abrasions sur la gaine.
- Remplacer les parties endommagées qui peuvent compromettre l'intégrité du système de gouvernement.

6.2 Entretien extraordinaire

Assistance technique

Pour toute information ou pour l'assistance relative des applications particulières, nous vous invitons contacter notre service d'assistance technique (Voir paragraphe "Lettre d'information").

7 DEMOLITION

7.1 Démolition

Si le système de commande doit être mis hors service pour quelques raisons que ce soit, les règles fondamentales suivantes doivent être observées pour la protection de l'environnement.

Gaines, conduits flexibles, composants de matériel plastique ou non métalliques, devront être désassemblés et éliminés parment.

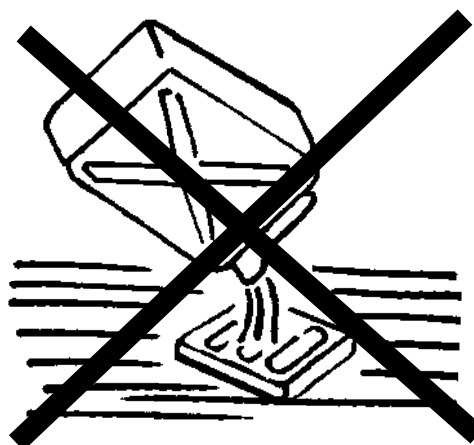

FRANÇAIS





ULTRAFLEX S.p.A.

16015 Casella (Genova) Italia - Via Crose, 2

