

# Quick®

CE REV 003A

**High Quality Nautical Equipment**

## **DP3 PRINCE SERIES** **700/1000/1500W**

**DP3 712**

**DP3 724**

**DP3 1012**

**DP3 1024**

**DP3 1512**

**DP3 1524**

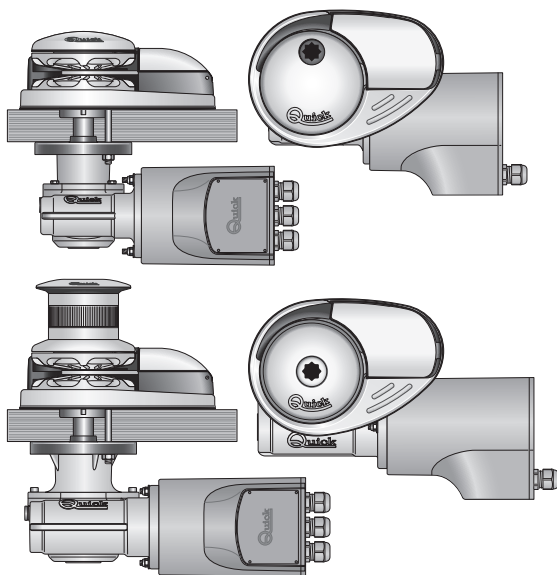

**IT**

Manuale d'uso

**GB**

User's Manual

**FR**

Manuel de l'utilisateur

**DE**

Benutzerhandbuch

**ES**

Manual del usuario

**SALPA ANCORA VERTICALI**

**VERTICAL WINDLASSES**

**GUINDEAUX VERTICAUX**

**VERTIKAL ANKERWINDEN**

**MOLINETES VERTICALES**

**IT****INDICE**

Pag. 4	Caratteristiche tecniche	Pag. 7	Usò - Avvertenze importanti
Pag. 5	Installazione	Pag. 8/9	Manutenzione
Pag. 6	Schema di collegamento	Pag. 10/11	Set

**GB****INDEX**

Pag. 12	Technical data	Pag. 15	Usage - Warning
Pag. 13	Installation	Pag. 16/17	Maintenance
Pag. 14	Connection diagram	Pag. 18/19	Set

**FR****SOMMAIRE**

Pag. 20	Caractéristiques techniques	Pag. 23	Utilisation - Avertissements importants
Pag. 21	Installation	Pag. 24/25	Entretien
Pag. 22	Schéma de câblage	Pag. 26/27	Groupe

**DE****INHALTSANGABE**

Seite 28	Technische Eigenschaften	Seite 31	Gebrauch - Wichtige Hinweise
Seite 29	Montage	Seite 32/33	Wartung
Seite 30	Anschlussplan	Seite 34/35	Gruppe

**ES****INDICE**

Pág. 36	Características técnicas	Pág. 39	Usò - Advertencias importantes
Pág. 37	Instalación	Pág. 40/41	Mantenimiento
Pág. 38	Esquema de montaje	Pág. 42/43	Grupo

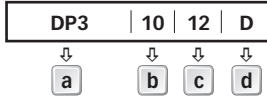
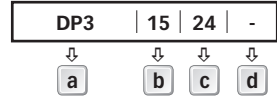
**HOW TO IDENTIFY THE WINDLASS THROUGH THE CODE:**
**1° EXAMPLE:**  
 DP31012D

**2° EXAMPLE:**  
 DP31524

a

**Name of the line:**  
 [ DP3 ]

b

**Motor power:**  
 [ 7 ] = 700 W  
 [ 10 ] = 1000 W  
 [ 15 ] = 1500 W

c

**Motor supply voltage:**  
 [ 12 ] = 12 V  
 [ 24 ] = 24 V

d

**Drum:**  
 [ D ] = with drum  
 [ - ] = without drum

MODEL	DP3 - / D						
MOTOR POWER	700W		1000W		1500W		
Motor supply voltage	12V	24V	12V	24V	12V	24V	
Maximum pull	850 Kg (1873,9 lb)		1000 Kg (2204,6 lb)		1100 Kg (2425,1 lb)		
Maximum working load	250 Kg (551,1 lb)	300 Kg (661,4 lb)	370 Kg (815,7 lb)	450 Kg (992 lb)	470 kg (1036,2 lb)	540 kg (1190,5 lb)	
Working load	80 Kg (176,4 lb)	100 Kg (220,5 lb)	120 kg (264,5 lb)	150 Kg (330,7 lb)	160 Kg (352,7 lb)	180 kg (396,8 lb)	
Current absorption working load (1)	90 A	55 A	140 A	80 A	155 A	85 A	
Maximum chain speed (2)	m/min	27,4 (89,9 ft/min)	26,4 (86,6 ft/min)	39,6 (129,9 ft/min)	40,9 (134,2 ft/min)	29,2 (95,8 ft/min)	29,7 (97,4 ft/min)
Maximum chain speed @ working load (2)	m/min	14,4 (47,2 ft/min)	14,8 (48,5 ft/min)	20,4 (66,9 ft/min)	21,4 (70,2 ft/min)	16,3 (53,5 ft/min)	19,0 (62,3 ft/min)
Motor cable size (3)	25 mm <sup>2</sup> (AWG3)		10 mm <sup>2</sup> (AWG7)	35 mm <sup>2</sup> (AWG2)	16 mm <sup>2</sup> (AWG5)	50 mm <sup>2</sup> (AWG0)	25 mm <sup>2</sup> (AWG3)
Protection circuit breaker (4)	50 A		40 A	80 A	50 A	100 A	50 A
Deck thickness (5)	25 ÷ 50 mm (63/64" ÷ 1" 31/32)				30 ÷ 50 mm (1" 3/16" ÷ 1" 31/32)		
Weight modell without drum	17,0 Kg (37,4 lb)		18,1 Kg (39,9 lb)		20,4 Kg (44,9 lb)		
Weight modell with drum	18,0 Kg (39,6 lb)		19,1 Kg (42,1 lb)		21,4 Kg (47,1 lb)		

(1) After an initial period of use.

(2) Measurements taken with a gypsy for a 8 mm chain.

(3) Minimum allowable value for a total length L&lt;20m. Determine the cable size according to the length of the wiring.

(4) With circuit breaker designed for direct currents (DC) and delayed-action (thermal-magnetic or hydraulic-magnetic).

(5) On request, shafts and studs can be supplied for greater deck thicknesses.

GYPSIES	8 mm - 5/16"				10 mm - 3/8"	
Chain size	8 mm	8 mm	5/16"	5/16"	10 mm	3/8"
	DIN 766	ISO	G4	BBB	ISO (P. 30)	G4
Rope size (*)	1/2" (12,7 mm) - 9/16" (14,2 mm) - 5/8" (15,8 mm)				5/8" (15,8 mm)	

(\*) The values indicated in the table refer to a rope and chain combination manufactured with the Quick® system, do not guarantee the correct functioning with other types of anchor-rode.

**Models' dimensions on page 44/46**

Quick® reserves the right to introduce changes to the equipment and the contents of this manual without prior notice.

In case of discordance or errors in translation between the translated version and the original text in the Italian language, reference will be made to the Italian or English text.



## BEFORE USING THE WINDLASS READ THESE INSTRUCTIONS CAREFULLY. IF IN DOUBT, CONTACT YOUR NEAREST "QUICK" DEALER.

**WARNING:** the Quick® windlasses are designed to weigh the anchor. ⚠ Do not use the equipment for other purposes.

- ⚠ Quick® shall not be held responsible for damage to equipment and/or personal injury, caused by a faulty use of the equipment.
- ⚠ The windlass is not designed for the loads that might occur in extreme weather conditions (storms). ⚠ Always deactivate the windlass when not in use. ⚠ Check that there are no swimmers nearby before dropping anchor. ⚠ The splice between the rope and the chain must be tightly woven for the rope to slide easily into the gypsy shape. For any problem or request, feel free to contact Quick® Technical Service. ⚠ For improved safety we recommend installing at least two anchor windlass controls in case one is accidentally damaged. ⚠ We recommend the use of the Quick® hydraulic-magnetic switch as the motor safety switch.
- ⚠ Secure the chain with a further device before starting the navigation. ⚠ The contactor unit or reversing contactor unit must be installed in a point protected from accidental water contact. ⚠ After completing the anchorage, secure the chain or rope to fixed points such as chain stopper or bollard. ⚠ To prevent accidental releases, the anchor must be secured. The windlass shall not be used as the only securing device. ⚠ Isolate the windlass from the power system during navigation (switch the circuit breaker off) and lock the chain securing it to a fixed point of the boat.

**THE PACKAGE CONTAINS:** windlass (on deck unit + motorgearbox) - contactor unit - base gasket - drill template - handle - bolts and screws (for assembly) - user's manual - conditions of warranty.

**TOOLS REQUIRED FOR INSTALLATION:** drill and drill bits: Ø 9 mm (23/64") and Ø 11 mm (7/16"); hollow mill: Ø 65 mm (2"9/16) and Ø 67 mm (2"5/8) ; hexagonal wrench: 13 mm.

**"QUICK" ACCESSORIES RECOMMENDED:** anchoring RL control board (mod. 800) - Waterproof hand helds R/C (mod. HRC1002) - Foot switch (mod. 900) - Hydraulic-magnetic circuit breaker - Anchor chain counter (mod. CHC1102M and CHC1202M) - Radio control RRC (mod. R02, P02, H02).

**INSTALLATION REQUIREMENTS:** the windlass must be positioned with the gypsy aligned with the bow roller. Ensure that the upper and lower surfaces of the deck are as parallel as possible. If this is not the case, compensate the difference appropriately (a lack of parallelism could result in a loss of motor power). The deck thickness must be included among the figures listed in the table. In cases of other thicknesses it is necessary to consult a Quick® retailer. There must be no obstacles under deck to the passage of cables, rope and chain; lack of depth of the peak could cause jamming.

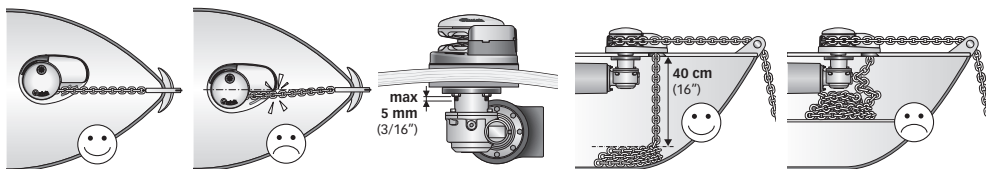

**FITTING PROCEDURE:** when the ideal position has been established, drill four holes using the drilling template provided. Remove excess material from the chain passage, refine and flatten with a specialized product (marine paint, gel coat or two pack epoxy) to assure free passage for both rope and chain. Position the upper section, inserting the gasket between the deck and the base and connect the lower section to the assembly, inserting the shaft into the reduction unit. Fix the windlass by screwing the nuts onto the fixing studs. Connect the supply cables from the windlass to the contactor unit.

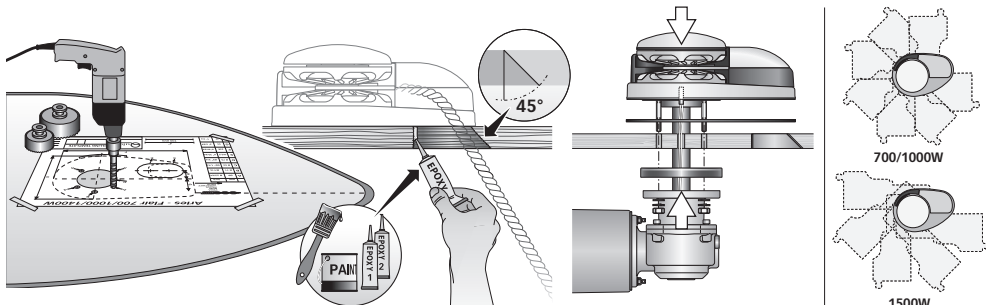

**⚠ WARNING:** before wiring up, be sure the electrical cables are not live.

Available motorgearboxes positioning



## BASIC SYSTEM

MULTI-PURPOSE  
WATERTIGHT HAND HELD  
REMOTE CONTROL  
MOD. HRC 1002

WINDLASS

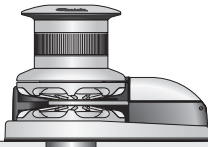

### QUICK® ACCESSORIES FOR WINDLASS OPERATION



WATERTIGHT HAND HELD  
CHAIN COUNTER

WINDLASSES  
CONTROL  
BOARD



WATERTIGHT  
PANEL  
CHAIN COUNTER



### REMOTE RADIO CONTROLS

RECEIVER

TRANSMITTERS

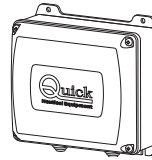

RADIO POCKET HANDHELD

FOOT SWITCHES MOD. 900U AND 900D

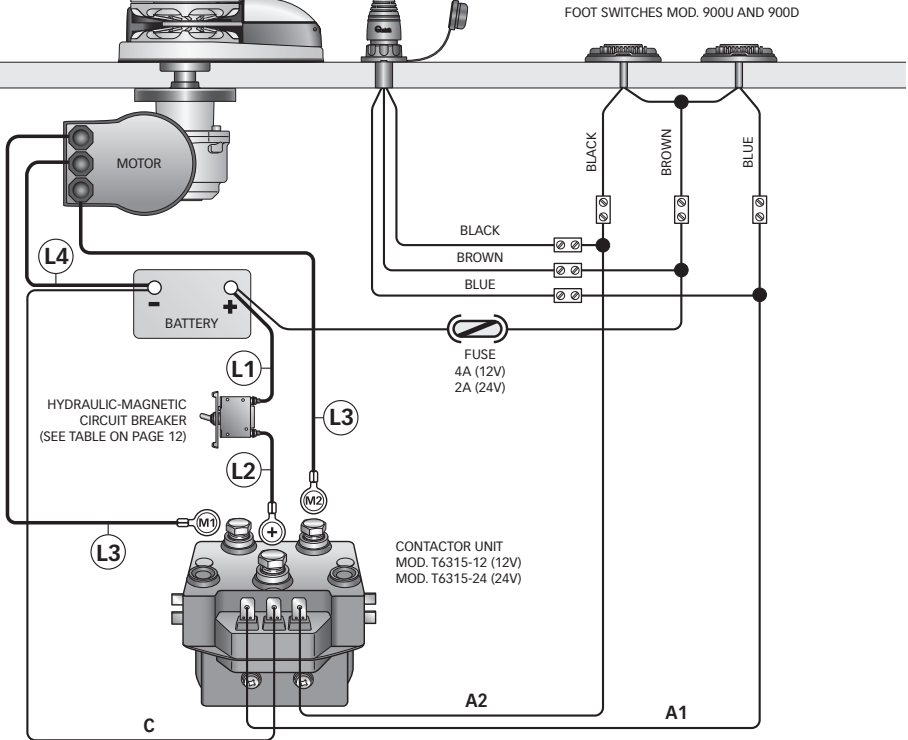

$$L = (L1) + (L2) + (L3) + (L4)$$



## WARNING



**WARNING:** stay clear of the chains, ropes and gypsy. Make sure the electric motor is off when windlass is used manually (even when using the handle to disengage the clutch). In fact people with windlass remote controls (hand-held remote control or radio-controlled systems) might accidentally operate it.



**WARNING:** secure the chain with a device before starting the navigation.



**WARNING:** do not operate the windlass by using the electrical power when the handle is inserted in the drum or into the gypsy cover.



**WARNING:** Quick® suggests the use of a protection such as a fuse/thermal-magnetic/ hydraulic-magnetic circuit breaker of suitable power according to the motor chosen, in order to protect it from any overheating or short circuits. The circuit breaker can be used to cut off power to the windlass control circuit and so avoid accidental activation.

## CLUTCH USE

The clutch (6 and 8) provides a link between the gypsy (7) and the main shaft (16 or 18). The clutch can be released (disengagement) by using the handle (1) which, when inserted in the bush (3) of the drum or into the gypsy cover (5), must be turned counter-clockwise. The clutch will be re-engaged by turning it clockwise (engagement).

## WEIGHING THE ANCHOR

Turn on the engine. Make sure the clutch is engaged and remove the handle (1).

Press the UP button on the control provided.

If the windlass stops and the hydraulic magnetic switch (or thermal cutout) has not tripped, wait a few seconds and try again (avoid keeping the button pressed).

If the hydraulic magnetic switch, has tripped, reset it and wait a few minutes before weighing anchor once again.

If, after a number of attempts, the windlass is still blocked, we suggest to move the boat to release the anchor. Check the upward movement of the chain for the last few meters in order to avoid damages to the bow.

## CASTING THE ANCHOR

The anchor can be cast by using the electrical control or manually. To operate manually, the clutch (6 and 8) must be disengaged allowing the gypsy (7) to revolve and letting the rope or chain fall into the water.

To slow down the chain, the handle (1) must be turned clockwise.

To cast the anchor by using the electrical power, press the DOWN button on the control provided. In this manner, anchor casting is under control and the chain and rope unwind evenly.

In order to avoid any stress on the windlass -once the boat is anchored- fasten the chain or secure it in place with a rope.

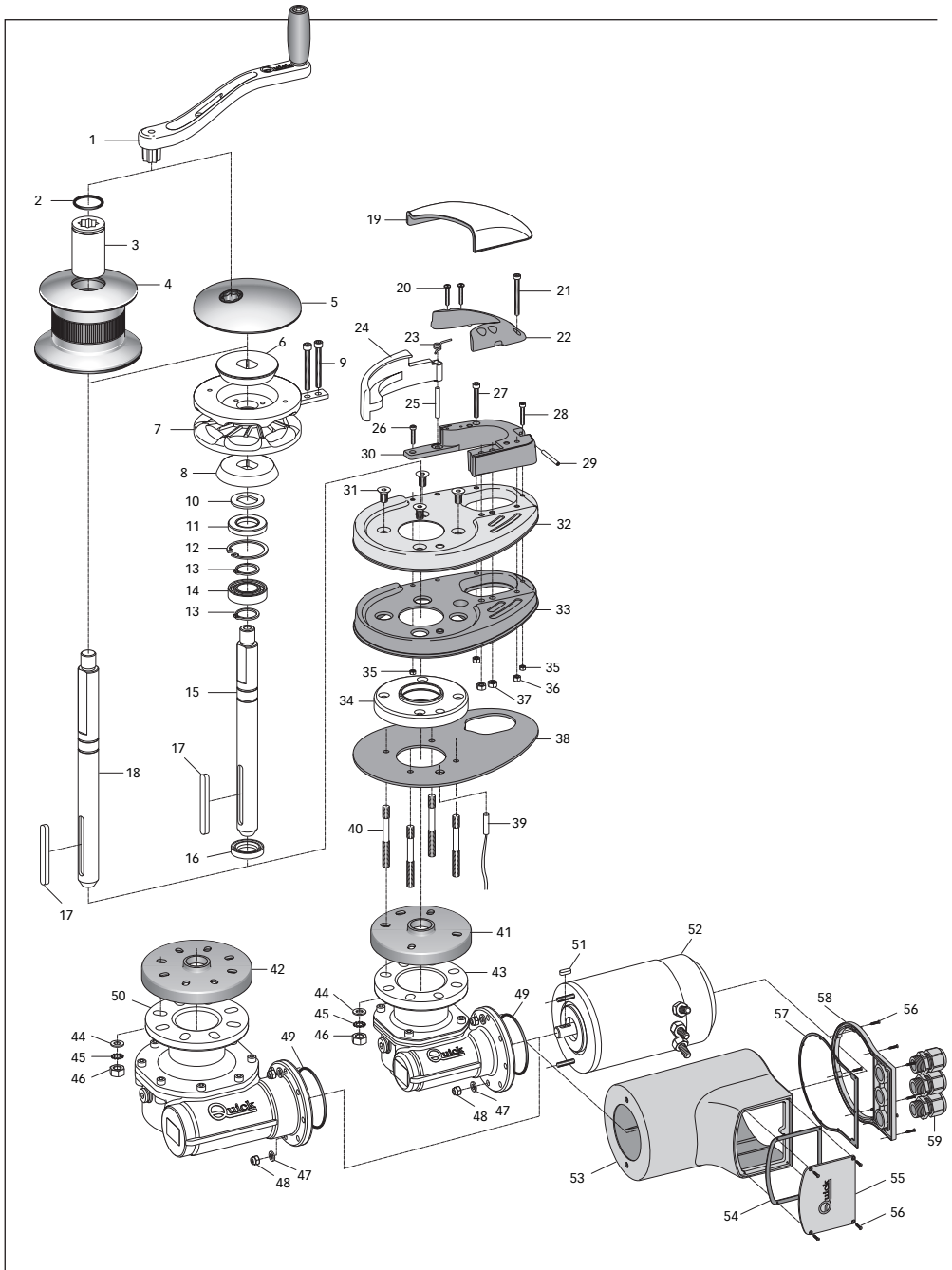



N.	DESCRIPTION				
1	Bent anchor winch lever	22	Mooring rope puller DP3	45	Grower
2	O-ring	23	Spring for pressure lever	46	Nut
3	Drum bush DP3 chromed	24	Pressure lever	47	Washer
4	Drum 1000W	25	Cylindrical stainless steel pin 5*40	48	Self locking nut
5	Gypsy cover	26	Screw M4*26 stainless steel	49	O-ring
6	Top clutch cone	27	Screw M5*40 stainless steel	50	Gearbox - Quick TG70 1500W
7A	Gypsy 8 mm	28	Screw M4*25 stainless steel	51	Key 5x5x15
7B	Gypsy 10 mm	29	Screw M4*40 stainless steel	52A	Electric motor 700W 12V
8	Bottom clutch cone	30	Plastic chain pipe series DP3	52B	Electric motor 700W 24V
9	Screw M 6*55 stainless steel	31	Screw M8*20 stainless steel	52C	Electric motor 1000W 12V
10	Spring washer	32	Cover Base DP3 stainless steel	52D	Electric motor 1000W 24V
11	Oil seal	33	Plastic cover insert DP3	52E	Electric motor 1500W 12V
12	Internal circlip	34	Aluminium round base DP3	52F	Electric motor 1500W 24V
13	External circlip	35	Nut M 4 stainless steel	53A	Motor protection case 700W
14	Bearing	36	Nut M 5 stainless steel	53B	Motor protection case 1000/1400W
15	Short shaft	37	Nut M 6 stainless steel	54	Grommet
16	Oil seal	38	Gasket/ DP3 - shaped jig	55	Terminal board cover
17	Key	39	Sensor	56	Screw
18	Long shaft	40	Stud 8*080 Ø8 stainless steel	57	Bottom gasket
19	Chain guide cover stainless steel	41	Gearbox flange gasket TOP TG50	58	Bottom protec cover
20	Screw 3,9*25 stainless steel	42	Gearbox flange gasket TOP TG60	59	Cable outlet
21	Screw M5*50 stainless steel	43	Gearbox - Quick TG50 1000W		
		44	Washer		



**WARNING:** make sure the electrical power to the motor is switched off when working manually on the windlass. Carefully remove the chain or rope from the gypsy or the rope from the drum.

Quick® windlasses are manufactured with materials resistant to marine environments. In any case, any salt deposits on the outside must be removed periodically to avoid corrosion and damage to the equipment. The parts where salt may have built up should be washed thoroughly with fresh water.

Once a year, the drum and the gypsy are to be taken apart as follows:

### DRUM VERSION

Use the handle (1) to loosen the bush (3); pull off the drum (4) and the top clutch cone (6); loosen the fixing screws (9) of the rope/chain stripper and remove it. Pull off the gypsy (7).

### NO-DRUM VERSION

Use the handle (1) to remove the gypsy cover (5); remove the top clutch cone (6); loosen the fixing screws (9) of the rope/chain stripper and remove it and pull off the gypsy (7).

Clean all the parts removed to avoid corrosion, and grease the shaft thread (15 or 18) and the gypsy (7) where the clutch cones (6 and 8) rest (use grease suitable for marine environment).

Remove any oxide deposits from the terminals of the electric motor and the contactor unit; grease them.



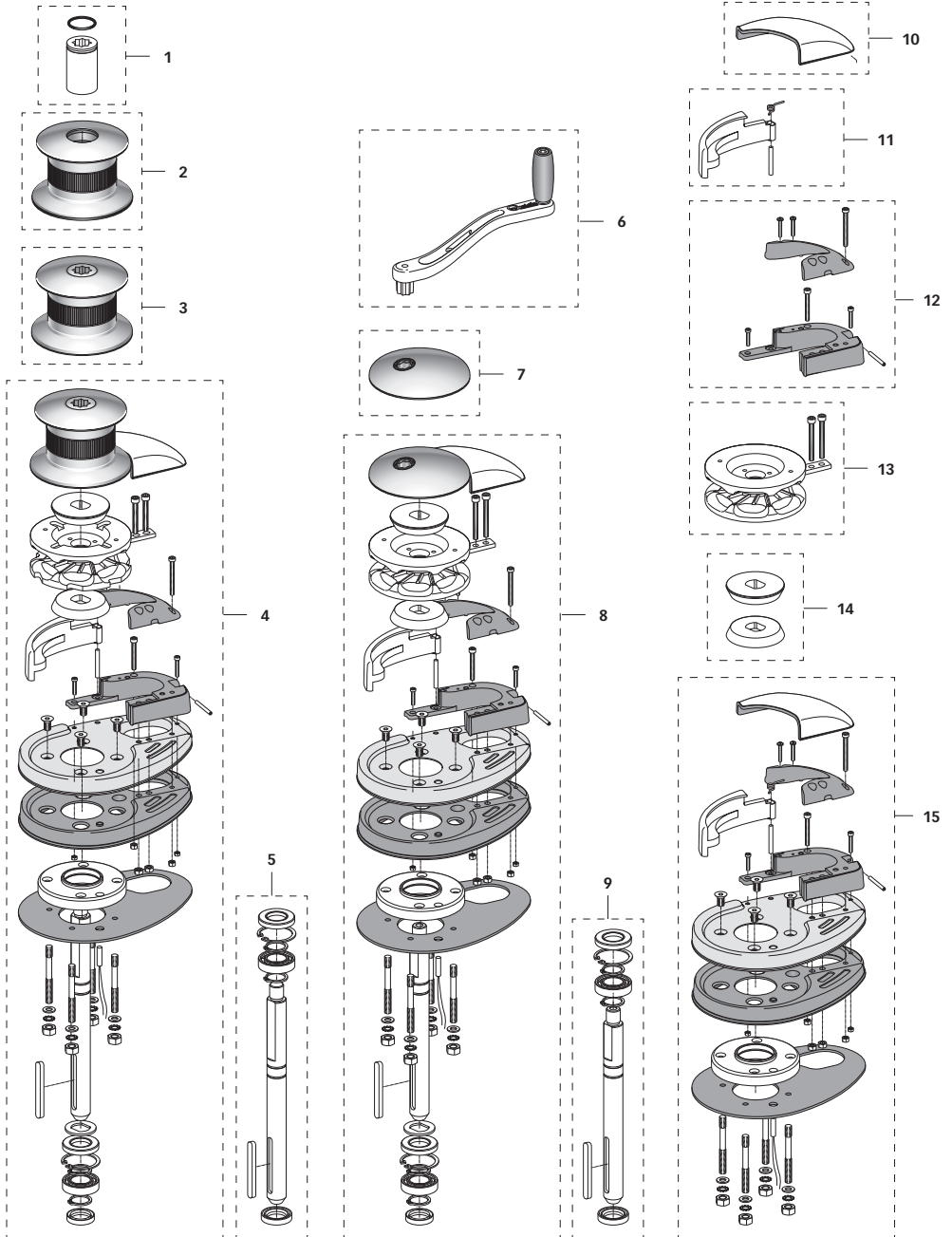



N.	OSP DESCRIPTION	CODE	16 A	OSP GEARBOX 1000W WINDL QUICK TG50	FVSSMR10TG50A00
1	OSP DRUM BUSH "SERIES DP3"	FVSSGMDP300000	16 B	OSP GEARBOX 1500W WINDL QUICK TG70	FVSSMR15TG70A00
2	OSP WINDLASS DRUM 1000W DP3	FVSSMSE10DP3A00	17 A	OSP MOTORGearBOX 700W 12V QUICK	FVSSR0712Q00A00
3	OSP WINDLASS DRUM 1000W COMPLET R03	FVSSMSE10000A03	17 B	OSP MOTORGearBOX 700W 24V QUICK	FVSSR0724Q00A00
4 A	OSP TOP DP3 D 8MM-5/16"	FVSTDP3D008A00	17 C	OSP MOTORGearBOX 1000W 12V QUICK	FVSSR1012Q00A00
4 B	OSP TOP DP3 D 10MM-3/8"	FVSTDP3D010A00	17 D	OSP MOTORGearBOX 1000W 24V QUICK	FVSSR1024Q00A00
5	OSP SHAFT DP3 D KIT	FVSSADP300D0A00	17 E	OSP MOTORGearBOX 1500W 12V QUICK	FVSSR1512Q00A00
6	OSP BENT ANCHOR WINCH LEVER R01	FVSSLVSP00R1A00	17 F	OSP MOTORGearBOX 1500W 24V QUICK	FVSSR1524Q00A00
7	OPS GYPSY COVER 1000W	FVSSCPBBA100A00	18 A	OSP ELECTRIC MOTOR WINDL 700W 12V	FVSSM0712000A00
8 A	OSP TOP DP3 8MM-5/16"	FVSTDP30008A00	18 B	OSP ELECTRIC MOTOR WINDL 700W 24V	FVSSM0724000A00
8 B	OSP TOP DP3 10MM-3/8"	FVSTDP30010A00	18 C	OSP ELECTRIC MOTOR WINDL 1000W 12V	FVSSM1012000A00
9	OSP SHAFT KIT DP3	FVSSADP30000A00	18 D	OSP ELECTRIC MOTOR WINDL 1000W 24V	FVSSM1024000A00
10	OSP CHAIN GUIDE COVER KIT DP3	FVSSPCSDP30A00	18 E	OSP ELECTRIC MOTOR WINDL 1500W 12V	FVSSM1512000A00
11	OSP PRESSURE LEVER DP3 KIT	FVSTCDP3000A00	18 F	OSP ELECTRIC MOTOR WINDL 1500W 24V	FVSSM1524000A00
12	OSP CHAIN PIPE DP3 KIT	FVSSPCSDP300A00			
13	OSP 8MM-5/16" GYPSY DP3	FVSSBDP38516A00			
14	OSP CLUTCH CONES DP3	FVSSCFANHC00A00			
15	OSP WINDLASS BASE SERIS DP3 COMP	FVSSBDP310C00A00			

16

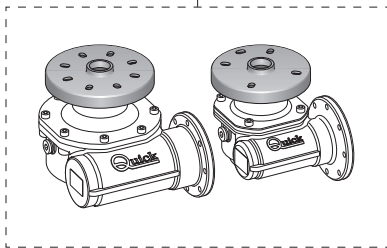

17

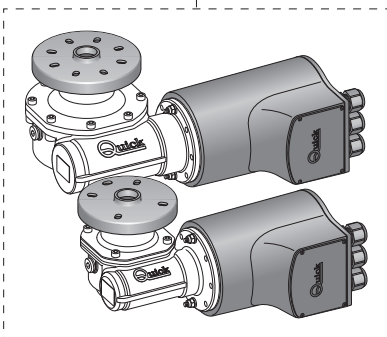

18

